

## HG+ – New hollow shaft precision

The successor to our versatile hypoid gearhead with hollow shaft on one/both sides



## HG+



Specifications \ Version	HG+		
	+	++	+++
Positioning accuracy		██████████	
Rigidity	██████████		
Smooth-running		██████████	
Speed capacity		██████████	
Power density	██████████		
Max. axial/radial forces		██████████	



Shrink disc

See our website and our separate flyer for more information about our washdown solutions

## Options

Plug-in drive coupling  
Washdown version  
ATEX version   
Food-grade grease 

## Accessories

Shrink disc (see page 342)

### The modular principle

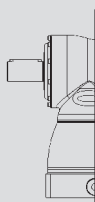

Shaft with key

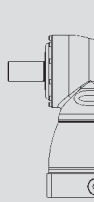

Smooth shaft



Hollow shaft



Closed cover

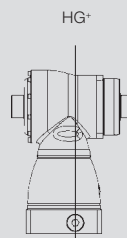

2 hollow shaft interfaces

# HG+ 060 MF 1/2-stage

		1-stage					2-stage											
Ratio <sup>a)</sup>	<i>i</i>	3	4	5	7	10	12	16	20	25	28	35	40	50	70	100		
Max. acceleration torque (max. 1000 cycles per hour)	$T_{2B}$	Nm	30	30	30	25	20	30	30	30	30	30	30	30	25	20		
		in.lb	266	266	266	221	177	266	266	266	266	266	266	266	266	221	177	
Nominal output torque (with $n_{2N}$ )	$T_{2N}$	Nm	22	22	22	20	15	22	22	22	22	22	22	22	20	15		
		in.lb	195	195	195	177	133	195	195	195	195	195	195	195	195	177	133	
Emergency stop torque (permitted 1000 times during the service life of the gearhead)	$T_{2Not}$	Nm	40	50	50	45	40	50	50	50	50	50	50	50	45	40		
		in.lb	354	443	443	398	354	443	443	443	443	443	443	443	443	398	354	
Nominal input speed (with $T_{2N}$ and 20°C ambient temperature) <sup>b), c)</sup>	$n_{1N}$	rpm	2500	2700	3000	3000	3000	4400	4400	4400	4400	4400	4400	4800	5500	5500		
Max. continuous speed (with 20% $T_{2N}$ and 20°C ambient temperature)	$n_{1Ncym}$	rpm	3000	3500	4000	3500	3500	5000	5000	5000	5000	5000	5000	5000	5500	5500		
Max. input speed	$n_{1Max}$	rpm	6000	6000	6000	6000	6000	6000	6000	6000	6000	6000	6000	6000	6000	6000		
Mean no load running torque (with $n_1=3000$ rpm and 20°C gearhead temperature) <sup>d)</sup>	$T_{012}$	Nm	1.3	1.2	1.1	1.3	1.2	0.2	0.2	0.2	0.2	0.2	0.2	0.1	0.1	0.1		
		in.lb	11.5	10.6	9.7	11.5	10.6	1.8	1.8	1.8	1.8	1.8	1.8	0.9	0.9	0.9		
Max. torsional backlash	$j_i$	arcmin	≤ 5															
Torsional rigidity	$C_{t21}$	Nm/ arcmin	2.2	2.3	2.4	2.2	1.9	2.3	2.3	2.3	2.3	2.3	2.3	2.3	2.4	2.2	1.9	
		in lb/ arcmin	19	20	21	19	17	20	20	20	20	20	20	20	21	19	17	
Max. axial force <sup>e)</sup>	$F_{2AMax}$	N	2400															
		lb <sub>f</sub>	540															
Max. radial force <sup>e)</sup>	$F_{2RMax}$	N	2700															
		lb <sub>f</sub>	608															
Max. tilting moment	$M_{2KMMax}$	Nm	251															
		in.lb	2220															
Efficiency at full load	$\eta$	%	96					94										
Service life (For calculation, see the Chapter "Information")	$L_h$	h	> 20000															
Weight incl. standard adapter plate	<i>m</i>	kg	2.9					3.2										
		lb <sub>m</sub>	6.4					7.1										
Operating noise (with $n_1=3000$ rpm no load)	$L_{PA}$	dB(A)	≤ 64															
Max. permitted housing temperature		°C	+90															
		F	194															
Ambient temperature		°C	0 to +40															
		F	32 to 104															
Lubrication			Lubricated for life															
Paint			Blue RAL 5002															
Direction of rotation			Motor and gearhead opposite directions															
Protection class			IP 65															
Moment of inertia (relates to the drive) Clamping hub diameter [mm]	B	11	$J_1$	kgcm <sup>2</sup>	-	-	-	-	-	0.09	0.09	0.07	0.07	0.06	0.06	0.06	0.06	
				10 <sup>-3</sup> in lb s <sup>2</sup>	-	-	-	-	-	0.08	0.08	0.07	0.06	0.06	0.06	0.05	0.05	0.05
	C	14	$J_1$	kgcm <sup>2</sup>	0.52	0.44	0.40	0.36	0.34	0.20	0.20	0.19	0.19	0.18	0.18	0.17	0.17	0.17
				10 <sup>-3</sup> in lb s <sup>2</sup>	0.46	0.39	0.35	0.32	0.30	0.18	0.18	0.17	0.16	0.16	0.16	0.15	0.15	0.15
E	19	$J_1$	kgcm <sup>2</sup>	0.87	0.79	0.75	0.71	0.70	-	-	-	-	-	-	-	-		
			10 <sup>-3</sup> in lb s <sup>2</sup>	0.77	0.70	0.66	0.63	0.62	-	-	-	-	-	-	-	-		

Please contact us for information on the best configuration for S1 conditions of use (continuous operation).

- <sup>a)</sup> Other ratios available on request
- <sup>b)</sup> Higher speeds are possible if the nominal torque is reduced
- <sup>c)</sup> For higher ambient temperatures, please contact us
- <sup>d)</sup> Idling torques decrease during operation
- <sup>e)</sup> Refers to center of the output shaft or flange

All technical data for front output side applies.  
Please request information for rear output side versions.

View A

1-stage:

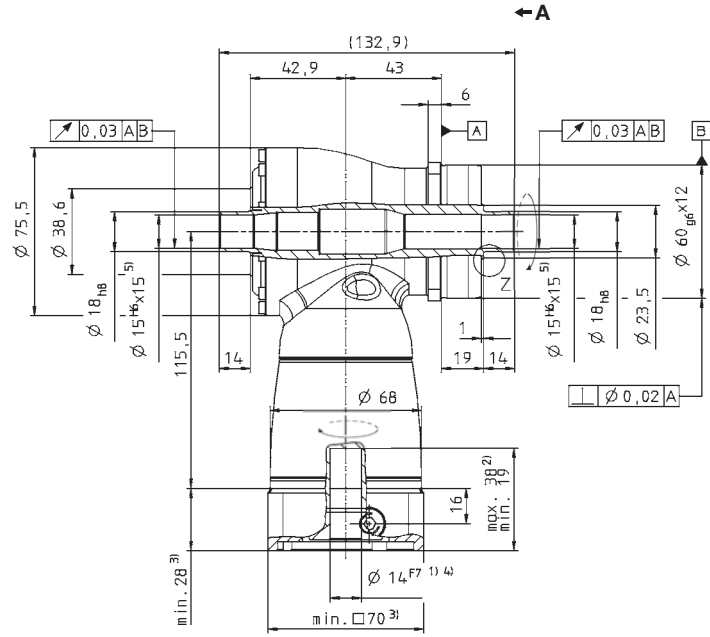
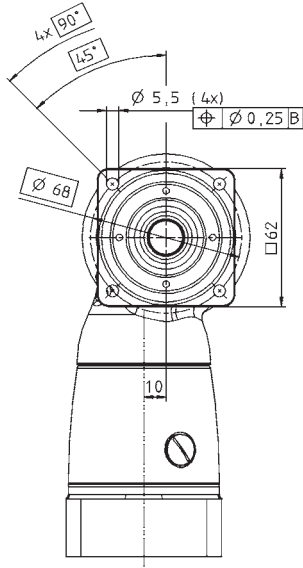

2-stage:

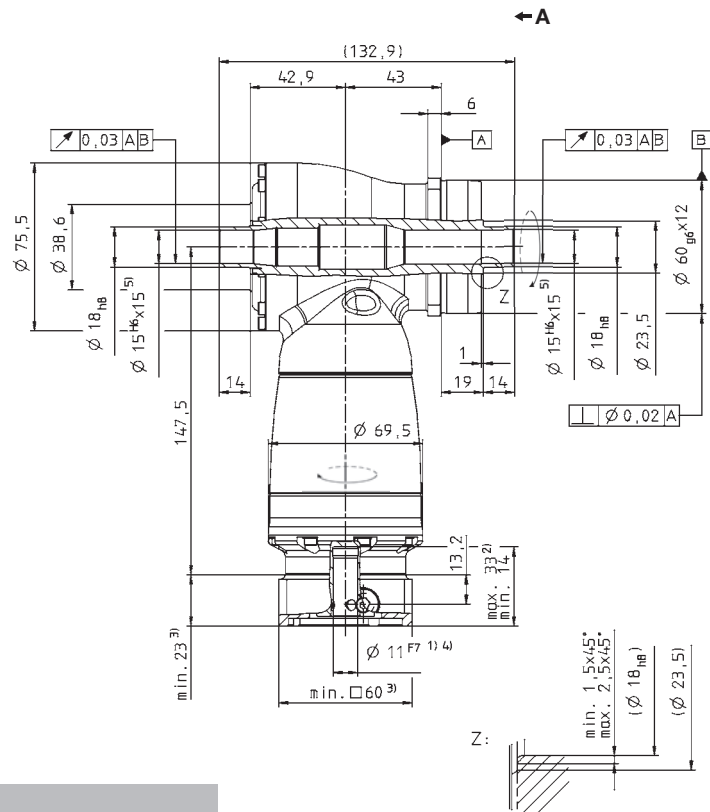
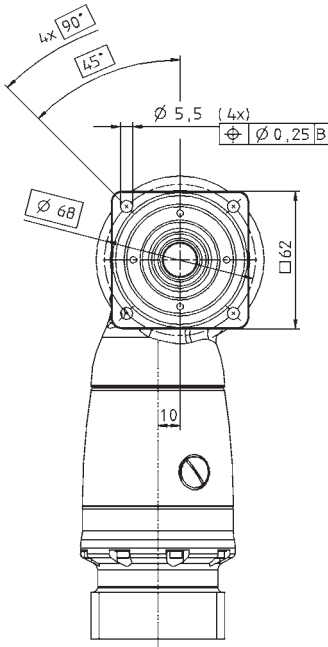

Alternatives: Single output shaft

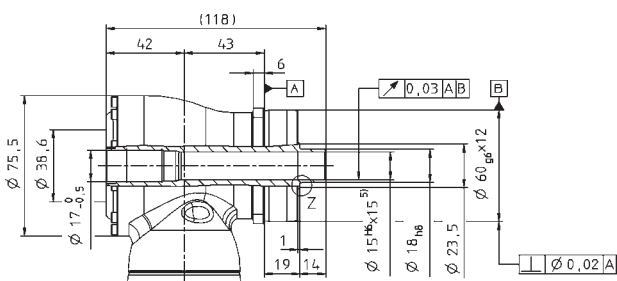

See technical data sheet for available clamping hub diameters (mass moment of inertia). Dimensions available on request.

Non-tolerated dimensions  $\pm 1$  mm

- 1) Check motor shaft fit.
- 2) Min./Max. permissible motor shaft length. Longer motor shafts are adaptable, please contact us.
- 3) The dimensions depend on the motor.
- 4) Smaller motor shaft diameter is compensated by a bushing with a minimum thickness of 1 mm.
- 5) Tolerance h6 for mounted shaft.

Motor mounting according to operating manual



# HG+ 075 MF 1/2-stage

		1-stage					2-stage													
Ratio <sup>a)</sup>	<i>i</i>	3	4	5	7	10	12	16	20	25	28	35	40	50	70	100				
Max. acceleration torque (max. 1000 cycles per hour)	$T_{2B}$	Nm	70	70	70	60	50	70	70	70	70	70	70	70	60	50				
		in.lb	620	620	620	531	443	620	620	620	620	620	620	620	620	531	443			
Nominal output torque (with $n_{2N}$ )	$T_{2N}$	Nm	50	50	50	45	40	50	50	50	50	50	50	50	45	40				
		in.lb	443	443	443	398	354	443	443	443	443	443	443	443	443	398	354			
Emergency stop torque (permitted 1000 times during the service life of the gearhead)	$T_{2Not}$	Nm	95	115	115	110	100	115	115	115	115	115	115	115	110	100				
		in.lb	841	1018	1018	974	885	1018	1018	1018	1018	1018	1018	1018	1018	974	885			
Nominal input speed (with $T_{2N}$ and 20°C ambient temperature) <sup>b), c)</sup>	$n_{1N}$	rpm	2300	2500	2800	2800	2800	3500	3500	3500	3500	3500	3500	3800	4500	4500				
Max. continuous speed (with 207% $T_{2N}$ and 20°C ambient temperature)	$n_{1Ncym}$	rpm	3000	3500	4000	3500	3500	4500	4500	4500	4500	4500	4500	4500	4500	4500				
Max. input speed	$n_{1Max}$	rpm	6000	6000	6000	6000	6000	6000	6000	6000	6000	6000	6000	6000	6000	6000				
Mean no load running torque (with $n_1=3000$ rpm and 20°C gearhead temperature) <sup>d)</sup>	$T_{012}$	Nm	2.2	1.9	1.7	2.2	2.0	0.3	0.3	0.2	0.2	0.2	0.2	0.1	0.1	0.1				
		in.lb	19	17	15	19	18	2.7	2.7	1.8	1.8	1.8	1.8	0.9	0.9	0.9				
Max. torsional backlash	$j_i$	arcmin	≤ 4																	
Torsional rigidity	$C_{t21}$	Nm/arcmin	5.3	5.9	6.7	6.6	6.5	5.9	5.9	5.9	5.9	5.9	5.9	5.9	6.7	6.6	6.5			
		in.lb/arcmin	47	52	60	58	57	52	52	52	52	52	52	52	59	58	58			
Max. axial force <sup>e)</sup>	$F_{2AMax}$	N	3400																	
		lb <sub>f</sub>	765																	
Max. radial force <sup>e)</sup>	$F_{2RMax}$	N	4000																	
		lb <sub>f</sub>	900																	
Max. tilting moment	$M_{2KMMax}$	Nm	437																	
		in.lb	3867																	
Efficiency at full load	$\eta$	%	96					94												
Service life (For calculation, see the Chapter "Information")	$L_h$	h	> 20000																	
Weight incl. standard adapter plate	<i>m</i>	kg	4.8					5.1												
		lb <sub>m</sub>	10.6					11.3												
Operating noise (with $n_1=3000$ rpm no load)	$L_{PA}$	dB(A)	≤ 66																	
Max. permitted housing temperature		°C	+90																	
		F	194																	
Ambient temperature		°C	0 to +40																	
		F	32 to 104																	
Lubrication			Lubricated for life																	
Paint			Blue RAL 5002																	
Direction of rotation			Motor and gearhead opposite directions																	
Protection class			IP 65																	
Moment of inertia (relates to the drive) Clamping hub diameter [mm]	C	14	$J_1$	kgcm <sup>2</sup>	-	-	-	-	-	0.28	0.27	0.23	0.23	0.20	0.20	0.18	0.18	0.18	0.18	
				10 <sup>-3</sup> in lb s <sup>2</sup>	-	-	-	-	-	0.25	0.24	0.21	0.20	0.18	0.18	0.16	0.16	0.16	0.16	
	E	19	$J_1$	kgcm <sup>2</sup>	1.46	1.19	1.06	0.95	0.90	0.73	0.71	0.68	0.67	0.63	0.62	0.63	0.63	0.63	0.63	0.63
				10 <sup>-3</sup> in lb s <sup>2</sup>	1.29	1.05	0.94	0.84	0.79	0.64	0.63	0.60	0.59	0.55	0.55	0.56	0.55	0.55	0.55	
H	28	$J_1$	kgcm <sup>2</sup>	2.86	2.60	2.47	2.36	2.31	-	-	-	-	-	-	-	-	-	-		
			10 <sup>-3</sup> in lb s <sup>2</sup>	2.53	2.30	2.19	2.09	2.04	-	-	-	-	-	-	-	-	-	-		

Please contact us for information on the best configuration for S1 conditions of use (continuous operation).

- <sup>a)</sup> Other ratios available on request
- <sup>b)</sup> Higher speeds are possible if the nominal torque is reduced
- <sup>c)</sup> For higher ambient temperatures, please contact us
- <sup>d)</sup> Idling torques decrease during operation
- <sup>e)</sup> Refers to center of the output shaft or flange

All technical data for front output side applies.  
Please request information for rear output side versions.

View A

1-stage:

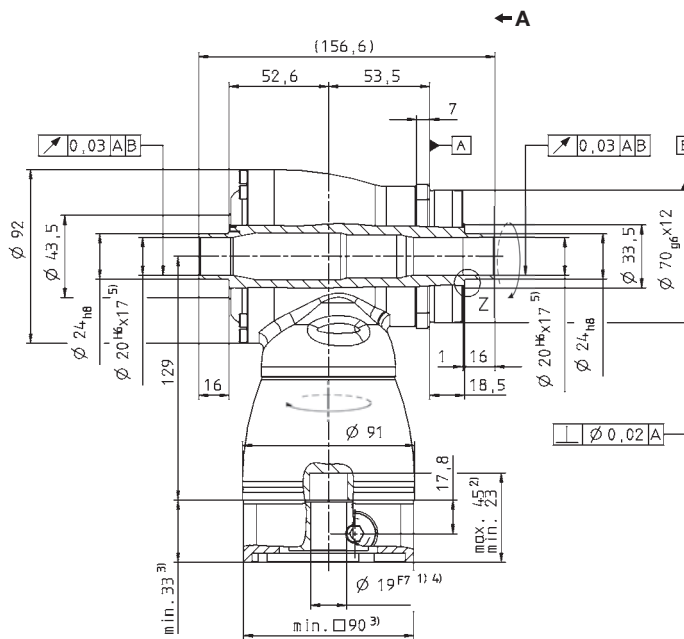
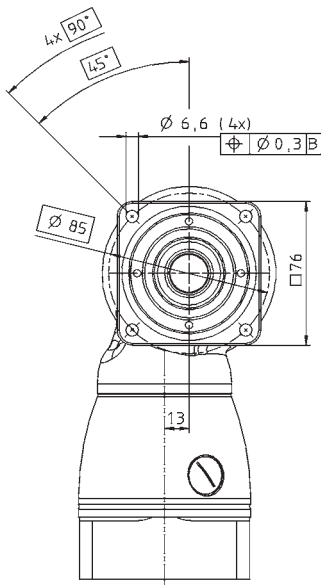

2-stage:

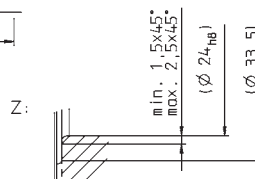
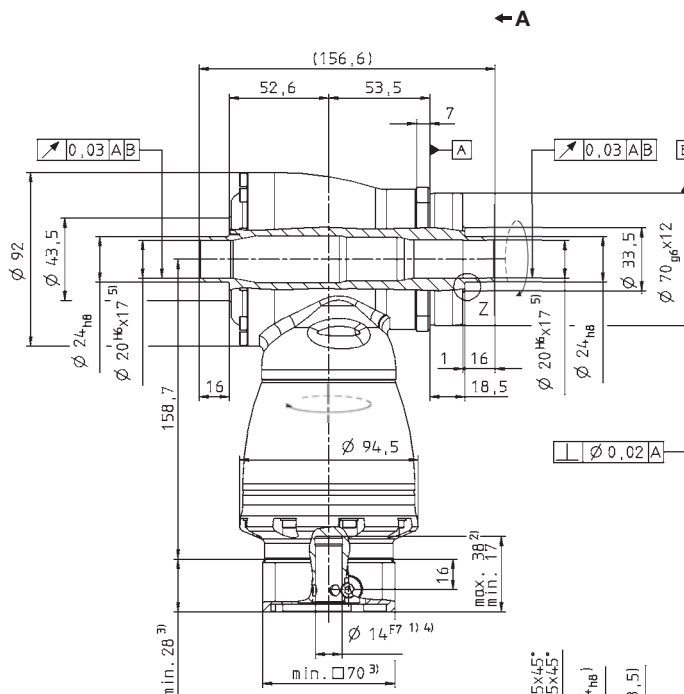
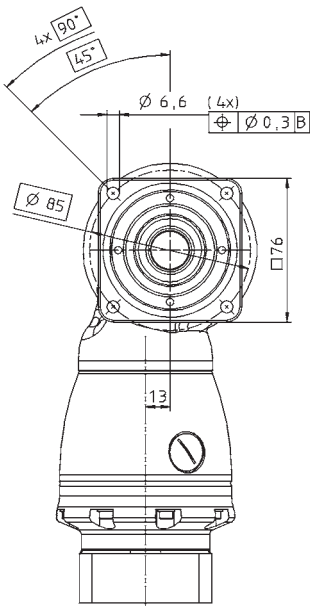

Alternatives: Single output shaft

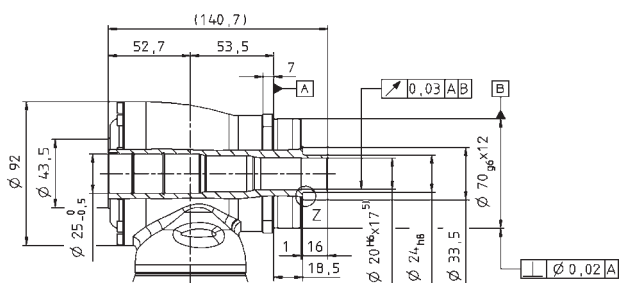

See technical data sheet for available clamping hub diameters (mass moment of inertia). Dimensions available on request.

Non-tolerated dimensions  $\pm 1$  mm

- 1) Check motor shaft fit.
- 2) Min./Max. permissible motor shaft length. Longer motor shafts are adaptable, please contact us.
- 3) The dimensions depend on the motor.
- 4) Smaller motor shaft diameter is compensated by a bushing with a minimum thickness of 1 mm.
- 5) Tolerance h6 for mounted shaft.

⚠ Motor mounting according to operating manual



# HG+ 100 MF 1/2-stage

		1-stage					2-stage													
Ratio <sup>a)</sup>	<i>i</i>	3	4	5	7	10	12	16	20	25	28	35	40	50	70	100				
Max. acceleration torque (max. 1000 cycles per hour)	$T_{2B}$	Nm	170	170	170	145	125	170	170	170	170	170	170	170	145	125				
		in.lb	1505	1505	1505	1283	1106	1505	1505	1505	1505	1505	1505	1505	1283	1106				
Nominal output torque (with $n_{2N}$ )	$T_{2N}$	Nm	100	100	100	90	80	100	100	100	100	100	100	100	90	80				
		in.lb	885	885	885	797	708	885	885	885	885	885	885	885	797	708				
Emergency stop torque (permitted 1000 times during the service life of the gearhead)	$T_{2Not}$	Nm	220	260	260	255	250	260	260	260	260	260	260	260	255	250				
		in.lb	1947	2301	2301	2257	2213	2301	2301	2301	2301	2301	2301	2301	2257	2213				
Nominal input speed (with $T_{2N}$ and 20°C ambient temperature) <sup>b), c)</sup>	$n_{1N}$	rpm	2200	2400	2700	2500	2500	3100	3100	3100	3100	3100	3100	3500	4200	4200				
Max. continuous speed (with 20% $T_{2N}$ and 20°C ambient temperature)	$n_{1Ncym}$	rpm	3000	3400	3800	3400	3400	4000	4000	4000	4000	4000	4000	4000	4200	4200				
Max. input speed	$n_{1Max}$	rpm	4500	4500	4500	4500	4500	4500	4500	4500	4500	4500	4500	4500	4500	4500				
Mean no load running torque (with $n_1=3000$ rpm and 20°C gearhead temperature) <sup>d)</sup>	$T_{012}$	Nm	4.2	3.3	2.5	3.9	3.1	0.7	0.7	0.6	0.4	0.4	0.3	0.2	0.2	0.2				
		in.lb	37	29	22	35	27	6.2	6.2	5.3	3.5	3.5	2.7	1.8	1.8	1.8				
Max. torsional backlash	$j_i$	arcmin	≤ 4																	
Torsional rigidity	$C_{i21}$	Nm/arcmin	10.7	12.1	14.0	14.2	14.4	12.1	12.1	12.1	12.1	12.1	12.1	12.1	14.0	14.2	14.4			
		in.lb/arcmin	95	107	124	126	127	107	107	107	107	107	107	107	124	126	127			
Max. axial force <sup>e)</sup>	$F_{2AMax}$	N	5700																	
		lb <sub>f</sub>	1283																	
Max. radial force <sup>e)</sup>	$F_{2RMax}$	N	6300																	
		lb <sub>f</sub>	1418																	
Max. tilting moment	$M_{2KMMax}$	Nm	833																	
		in.lb	7370																	
Efficiency at full load	$\eta$	%	96					94												
Service life (For calculation, see the Chapter "Information")	$L_h$	h	> 20000																	
Weight incl. standard adapter plate	<i>m</i>	kg	9.3					9.5												
		lb <sub>m</sub>	21					21												
Operating noise (with $n_1=3000$ rpm no load)	$L_{PA}$	dB(A)	≤ 66																	
Max. permitted housing temperature		°C	+90																	
		F	194																	
Ambient temperature		°C	0 to +40																	
		F	32 to 104																	
Lubrication			Lubricated for life																	
Paint			Blue RAL 5002																	
Direction of rotation			Motor and gearhead opposite directions																	
Protection class			IP 65																	
Moment of inertia (relates to the drive) Clamping hub diameter [mm]	E	19	$J_1$	kgcm <sup>2</sup>	-	-	-	-	-	1.02	0.97	0.86	0.84	0.75	0.74	0.69	0.69	0.68	0.68	
				10 <sup>-3</sup> in lb s <sup>2</sup>	-	-	-	-	-	0.91	0.86	0.76	0.74	0.66	0.66	0.61	0.61	0.60	0.60	
	G	24	$J_1$	kgcm <sup>2</sup>	-	-	-	-	-	2.59	2.54	2.42	2.40	2.31	2.30	2.26	2.25	2.25	2.25	2.25
				10 <sup>-3</sup> in lb s <sup>2</sup>	-	-	-	-	-	2.29	2.25	2.14	2.13	2.05	2.04	2.00	1.99	1.99	1.99	
	H	28	$J_1$	kgcm <sup>2</sup>	4.64	3.80	3.34	2.98	2.79	-	-	-	-	-	-	-	-	-	-	-
				10 <sup>-3</sup> in lb s <sup>2</sup>	4.10	3.36	2.95	2.64	2.47	-	-	-	-	-	-	-	-	-	-	-
	K	38	$J_1$	kgcm <sup>2</sup>	11.8	11.0	10.6	10.2	10.0	-	-	-	-	-	-	-	-	-	-	-
				10 <sup>-3</sup> in lb s <sup>2</sup>	10.4	9.73	9.34	9.04	8.88	-	-	-	-	-	-	-	-	-	-	-

Please contact us for information on the best configuration for S1 conditions of use (continuous operation).

- <sup>a)</sup> Other ratios available on request
- <sup>b)</sup> Higher speeds are possible if the nominal torque is reduced
- <sup>c)</sup> For higher ambient temperatures, please contact us
- <sup>d)</sup> Idling torques decrease during operation
- <sup>e)</sup> Refers to center of the output shaft or flange

All technical data for front output side applies.  
Please request information for rear output side versions.

View A

1-stage:

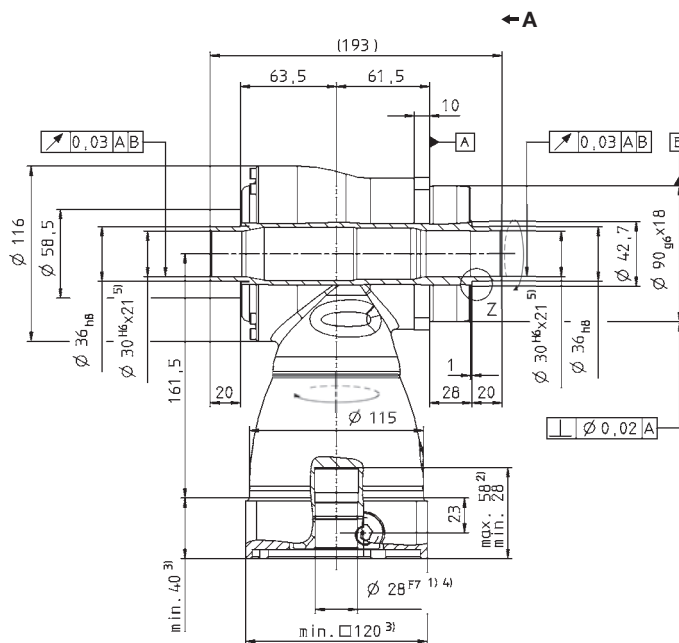
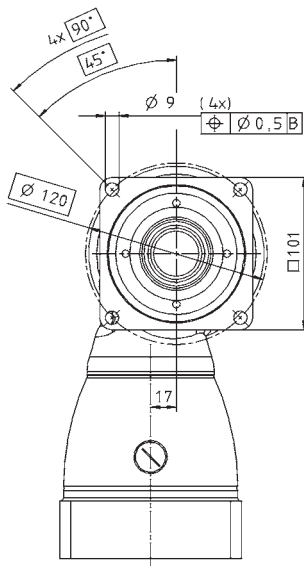

2-stage:

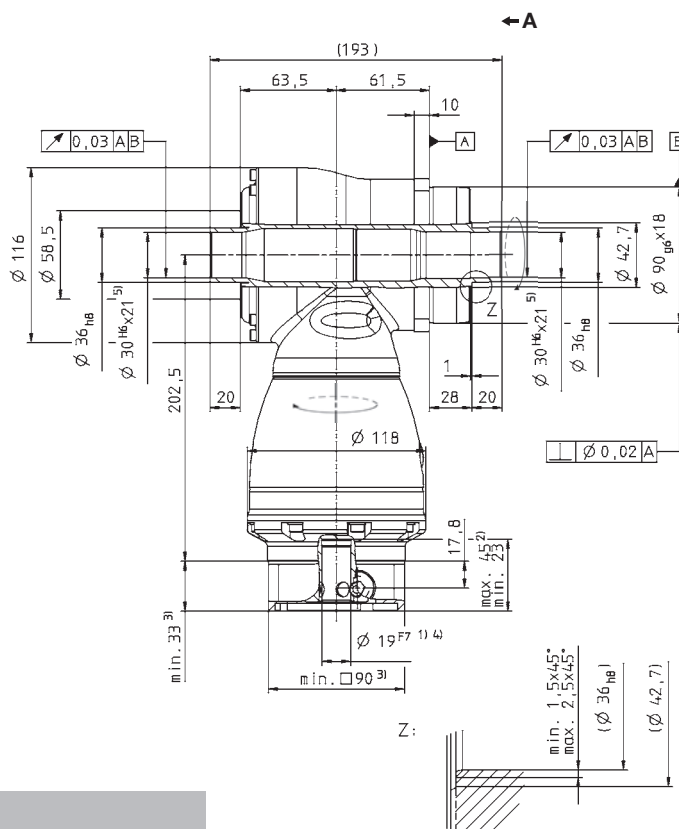
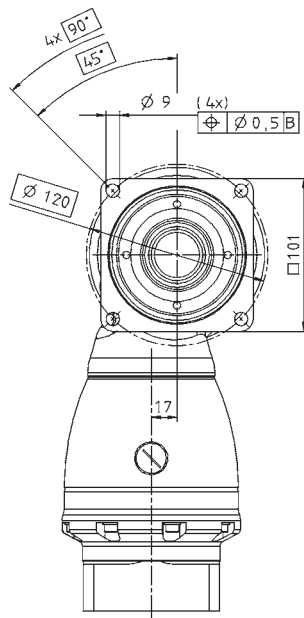

Alternatives: Single output shaft

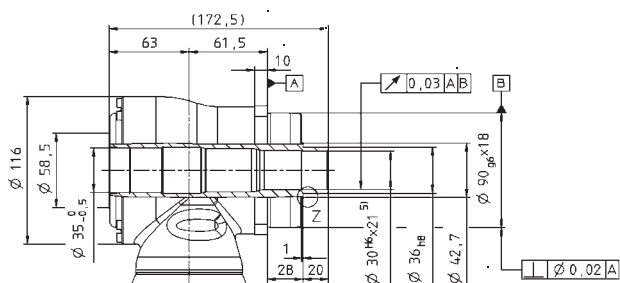

See technical data sheet for available clamping hub diameters (mass moment of inertia). Dimensions available on request.

Non-tolerated dimensions  $\pm 1$  mm

- 1) Check motor shaft fit.
- 2) Min./Max. permissible motor shaft length. Longer motor shafts are adaptable, please contact us.
- 3) The dimensions depend on the motor.
- 4) Smaller motor shaft diameter is compensated by a bushing with a minimum thickness of 1 mm.
- 5) Tolerance h6 for mounted shaft.

Motor mounting according to operating manual





# HG+ 140 MF 1/2-stage

		1-stage					2-stage												
Ratio <sup>a)</sup>	<i>i</i>	3	4	5	7	10	12	16	20	25	28	35	40	50	70	100			
Max. acceleration torque (max. 1000 cycles per hour)	$T_{2B}$	Nm	300	300	300	250	210	300	300	300	300	300	300	300	250	210			
		in.lb	2655	2655	2655	2213	1859	2655	2655	2655	2655	2655	2655	2655	2655	2213	1859		
Nominal output torque (with $n_{2N}$ )	$T_{2N}$	Nm	190	190	190	175	160	190	190	190	190	190	190	190	175	160			
		in.lb	1682	1682	1682	1549	1416	1682	1682	1682	1682	1682	1682	1682	1549	1416			
Emergency stop torque (permitted 1000 times during the service life of the gearhead)	$T_{2Not}$	Nm	400	500	500	450	400	500	500	500	500	500	500	500	450	400			
		in.lb	3540	4425	4425	3983	3540	4425	4425	4425	4425	4425	4425	4425	3983	3540			
Nominal input speed (with $T_{2N}$ and 20°C ambient temperature) <sup>b), c)</sup>	$n_{1N}$	rpm	1900	2000	2200	2000	2000	2900	2900	2900	2900	2900	2900	3200	3200	3900			
Max. continuous speed (with 20% $T_{2N}$ and 20°C ambient temperature)	$n_{1Ncym}$	rpm	2500	2800	3100	2800	2800	4000	4000	4000	4000	4000	4000	4200	4200	4200			
Max. input speed	$n_{1Max}$	rpm	4500	4500	4500	4500	4500	4500	4500	4500	4500	4500	4500	4500	4500	4500			
Mean no load running torque (with $n_1=3000$ rpm and 20°C gearhead temperature) <sup>d)</sup>	$T_{012}$	Nm	7.7	5.7	5.0	8.3	6.1	1.5	1.0	0.8	0.6	0.6	0.4	0.4	0.3	0.3			
		in.lb	68	50	44	73	54	13.3	8.9	7.1	5.3	5.3	3.5	3.5	2.7	2.7			
Max. torsional backlash	$j_i$	arcmin	≤ 4																
Torsional rigidity	$C_{t21}$	Nm/ arcmin	32	36	41	39	38	36	36	36	36	36	36	36	41	39	38		
		in lb/ arcmin	287	321	360	346	337	319	319	319	319	319	319	319	363	345	336		
Max. axial force <sup>e)</sup>	$F_{2AMax}$	N	9900																
		lb <sub>f</sub>	2228																
Max. radial force <sup>e)</sup>	$F_{2RMax}$	N	9500																
		lb <sub>f</sub>	2138																
Max. tilting moment	$M_{2KMax}$	Nm	1692																
		in.lb	14974																
Efficiency at full load	$\eta$	%	96					94											
Service life (For calculation, see the Chapter "Information")	$L_h$	h	> 20000																
Weight incl. standard adapter plate	<i>m</i>	kg	22.6					24											
		lb <sub>m</sub>	50					53											
Operating noise (with $n_1=3000$ rpm no load)	$L_{PA}$	dB(A)	≤ 68																
Max. permitted housing temperature		°C	+90																
		F	194																
Ambient temperature		°C	0 to +40																
		F	32 to 104																
Lubrication			Lubricated for life																
Paint			Blue RAL 5002																
Direction of rotation			Motor and gearhead opposite directions																
Protection class			IP 65																
Moment of inertia (relates to the drive) Clamping hub diameter [mm]	G	24	$J_1$	kgcm <sup>2</sup>	-	-	-	-	-	4.20	3.84	3.27	3.16	2.78	2.73	2.48	2.45	2.43	2.42
				10 <sup>-3</sup> in lb s <sup>2</sup>						3.71	3.40	2.90	2.80	2.46	2.41	2.20	2.17	2.15	2.14
	K	38	$J_1$	kgcm <sup>2</sup>	25.0	19.1	16.3	14.1	12.8	11.1	10.7	10.2	10.1	9.69	9.64	9.39	9.37	9.34	9.33
				10 <sup>-3</sup> in lb s <sup>2</sup>	22.1	16.9	14.4	12.4	11.3	9.83	9.51	9.01	8.92	8.58	8.53	8.31	8.29	8.27	8.26

Please contact us for information on the best configuration for S1 conditions of use (continuous operation).

- <sup>a)</sup> Other ratios available on request
- <sup>b)</sup> Higher speeds are possible if the nominal torque is reduced
- <sup>c)</sup> For higher ambient temperatures, please contact us
- <sup>d)</sup> Idling torques decrease during operation
- <sup>e)</sup> Refers to center of the output shaft or flange

All technical data for front output side applies.  
Please request information for rear output side versions.

View A

1-stage:

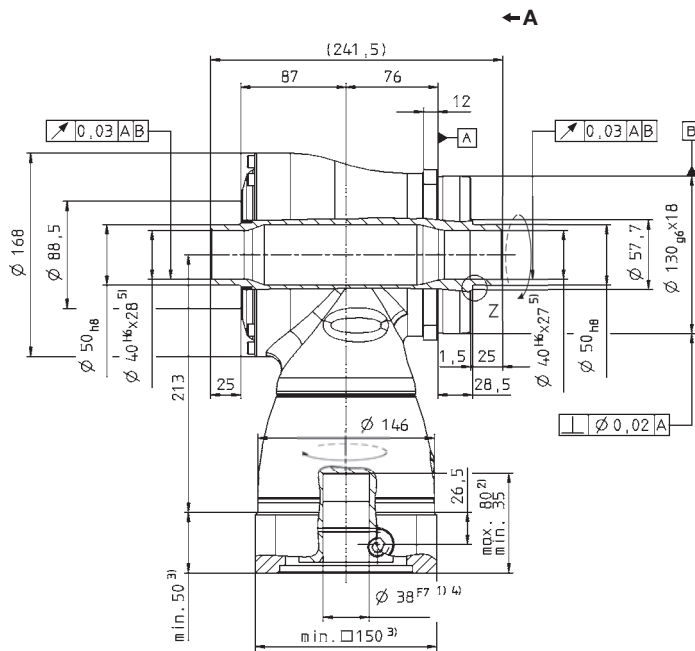
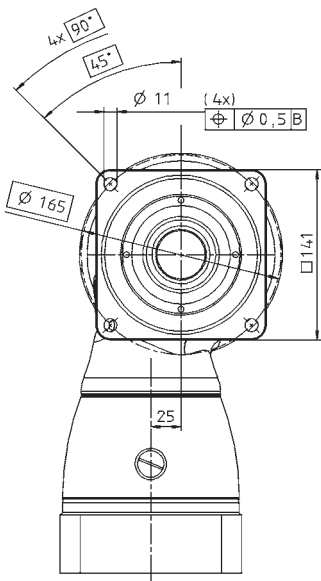

2-stage:

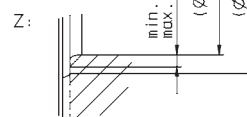
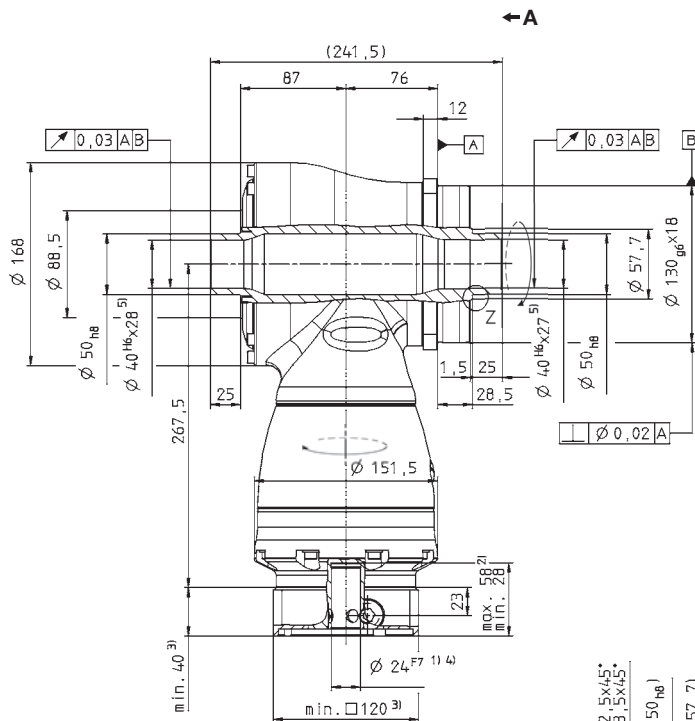
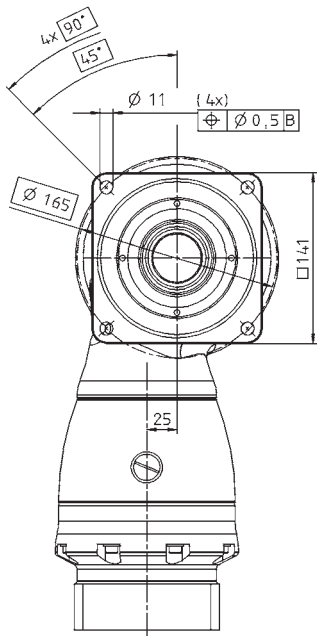

Alternatives: Single output shaft

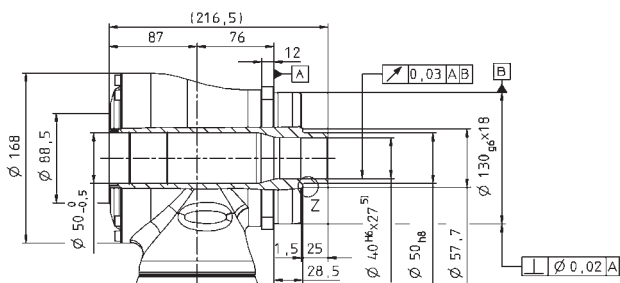

See technical data sheet for available clamping hub diameters (mass moment of inertia). Dimensions available on request.

Non-tolerated dimensions  $\pm 1$  mm

- 1) Check motor shaft fit.
- 2) Min./Max. permissible motor shaft length. Longer motor shafts are adaptable, please contact us.
- 3) The dimensions depend on the motor.
- 4) Smaller motor shaft diameter is compensated by a bushing with a minimum thickness of 1 mm.
- 5) Tolerance h6 for mounted shaft.

⚠ Motor mounting according to operating manual



# HG+ 180 MF 1/2-stage

		1-stage					2-stage												
Ratio <sup>a)</sup>	<i>i</i>	3	4	5	7	10	12	16	20	25	28	35	40	50	70	100			
Max. acceleration torque (max. 1000 cycles per hour)	$T_{2B}$	Nm	640	640	640	550	470	640	640	640	640	640	640	640	550	470			
		in.lb	5664	5664	5664	4868	4160	5664	5664	5664	5664	5664	5664	5664	4868	4160			
Nominal output torque (with $n_{2N}$ )	$T_{2N}$	Nm	400	400	400	380	360	400	400	400	400	400	400	400	380	360			
		in.lb	3540	3540	3540	3363	3186	3540	3540	3540	3540	3540	3540	3540	3363	3186			
Emergency stop torque (permitted 1000 times during the service life of the gearhead)	$T_{2Not}$	Nm	900	1050	1050	970	900	1050	1050	1050	1050	1050	1050	1050	970	900			
		in.lb	7965	9293	9293	8585	7965	9293	9293	9293	9293	9293	9293	9293	8585	7965			
Nominal input speed (with $T_{2N}$ and 20°C ambient temperature) <sup>b), c)</sup>	$n_{1N}$	rpm	1600	1800	2000	1800	1800	2700	2700	2700	2700	2700	2700	2900	3200	3400			
Max. continuous speed (with 20% $T_{2N}$ and 20°C ambient temperature)	$n_{1Ncym}$	rpm	2000	2400	2800	2500	2500	3500	3500	3500	3500	3500	3500	3500	3800	3800			
Max. input speed	$n_{1Max}$	rpm	4000	4000	4000	4000	4000	4000	4000	4000	4000	4000	4000	4000	4000	4000			
Mean no load running torque (with $n_1=3000$ rpm and 20°C gearhead temperature) <sup>d)</sup>	$T_{012}$	Nm	16.0	13.0	11.0	16.5	14.0	3.3	2.5	2.0	1.8	1.4	1.3	1.0	1.0	1.0			
		in.lb	142	115	97	146	124	29.2	22.1	17.7	15.9	12.4	11.5	8.9	8.9	8.9			
Max. torsional backlash	$j_i$	arcmin	≤ 4																
Torsional rigidity	$C_{t21}$	Nm/ arcmin	71	80	91	89	88	80	80	80	80	80	80	80	91	89	88		
		in lb/ arcmin	633	711	803	791	780	708	708	708	708	708	708	708	805	788	779		
Max. axial force <sup>e)</sup>	$F_{2AMax}$	N	14200																
		lb <sub>f</sub>	3195																
Max. radial force <sup>e)</sup>	$F_{2RMax}$	N	14700																
		lb <sub>f</sub>	3308																
Max. tilting moment	$M_{2KMMax}$	Nm	3213																
		in.lb	28435																
Efficiency at full load	$\eta$	%	96					94											
Service life (For calculation, see the Chapter "Information")	$L_h$	h	> 20000																
Weight incl. standard adapter plate	<i>m</i>	kg	45.4					47											
		lb <sub>m</sub>	100					104											
Operating noise (with $n_1=3000$ rpm no load)	$L_{PA}$	dB(A)	≤ 68																
Max. permitted housing temperature		°C	+90																
		F	194																
Ambient temperature		°C	0 to +40																
		F	32 to 104																
Lubrication			Lubricated for life																
Paint			Blue RAL 5002																
Direction of rotation			Motor and gearhead opposite directions																
Protection class			IP 65																
Moment of inertia (relates to the drive)	K	38	$J_1$	kgcm <sup>2</sup>	-	-	-	-	-	15.3	13.9	12.3	12.0	10.9	10.7	10.1	10.0	9.95	9.91
				10 <sup>-3</sup> in lb s <sup>2</sup>						13.5	12.3	10.9	10.6	9.65	9.48	8.96	8.88	8.80	8.77
Clamping hub diameter [mm]	M	48	$J_1$	kgcm <sup>2</sup>	73.3	51.6	42.1	34.0	29.7	30.0	28.7	27.0	26.7	25.6	25.4	24.8	24.7	24.7	24.6
				10 <sup>-3</sup> in lb s <sup>2</sup>	64.9	45.6	37.3	30.1	26.3	26.6	25.4	23.9	23.6	22.7	22.5	22.0	21.9	21.8	

Please contact us for information on the best configuration for S1 conditions of use (continuous operation).

- <sup>a)</sup> Other ratios available on request
- <sup>b)</sup> Higher speeds are possible if the nominal torque is reduced
- <sup>c)</sup> For higher ambient temperatures, please contact us
- <sup>d)</sup> Idling torques decrease during operation
- <sup>e)</sup> Refers to center of the output shaft or flange

All technical data for front output side applies.  
Please request information for rear output side versions.

View A

1-stage:

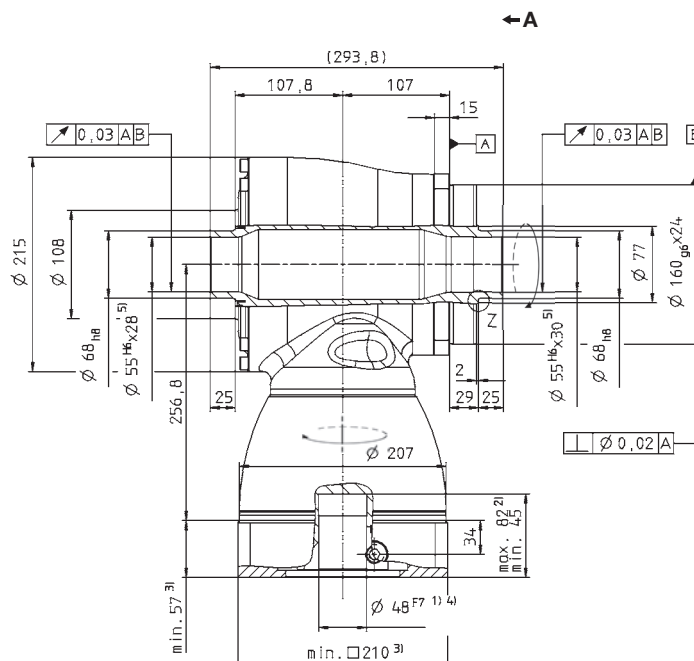
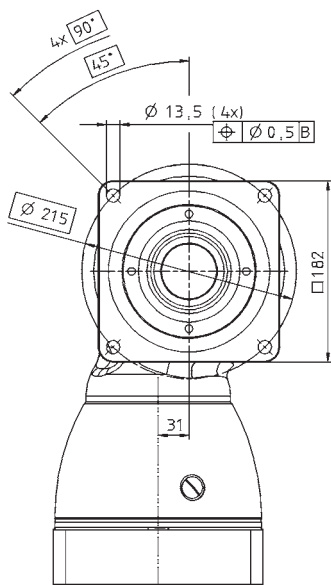

2-stage:

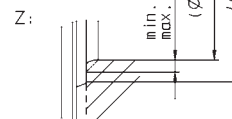
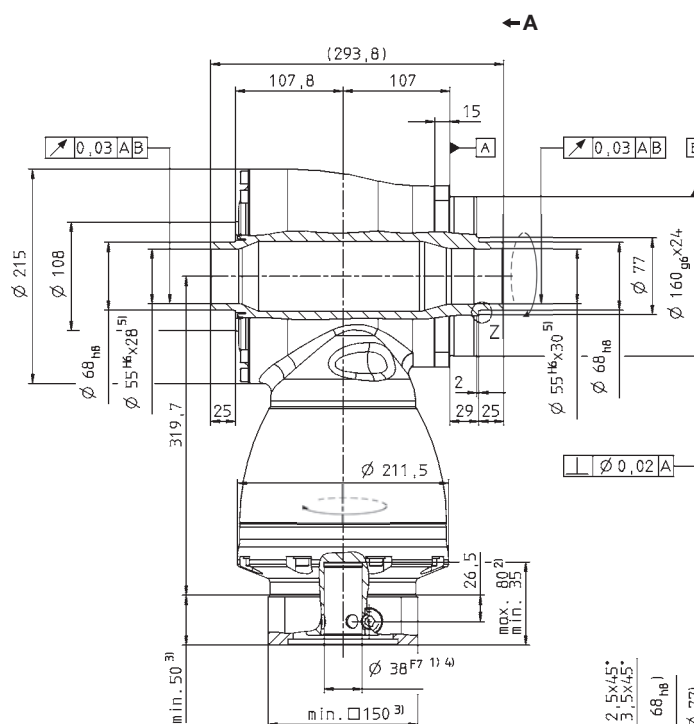
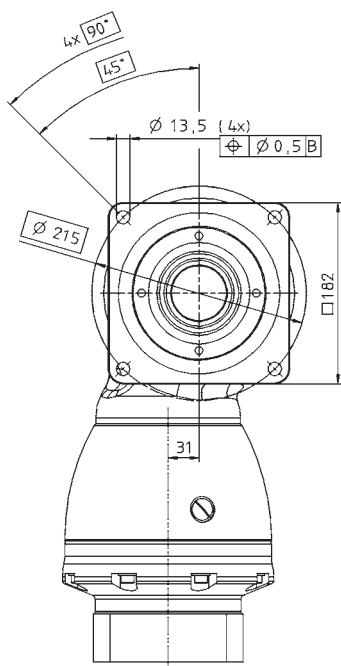

Alternatives: Single output shaft

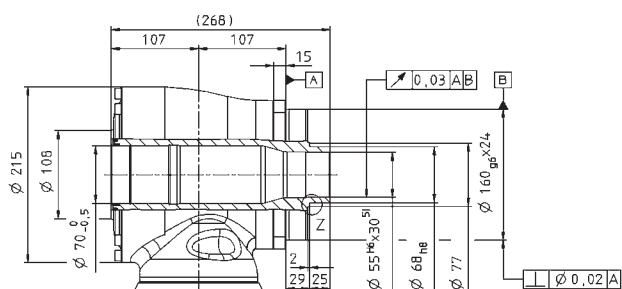

See technical data sheet for available clamping hub diameters (mass moment of inertia). Dimensions available on request.

Non-tolerated dimensions  $\pm 1$  mm

- 1) Check motor shaft fit.
- 2) Min./Max. permissible motor shaft length. Longer motor shafts are adaptable, please contact us.
- 3) The dimensions depend on the motor.
- 4) Smaller motor shaft diameter is compensated by a bushing with a minimum thickness of 1 mm.
- 5) Tolerance h6 for mounted shaft.

Motor mounting according to operating manual





## alpha HG+

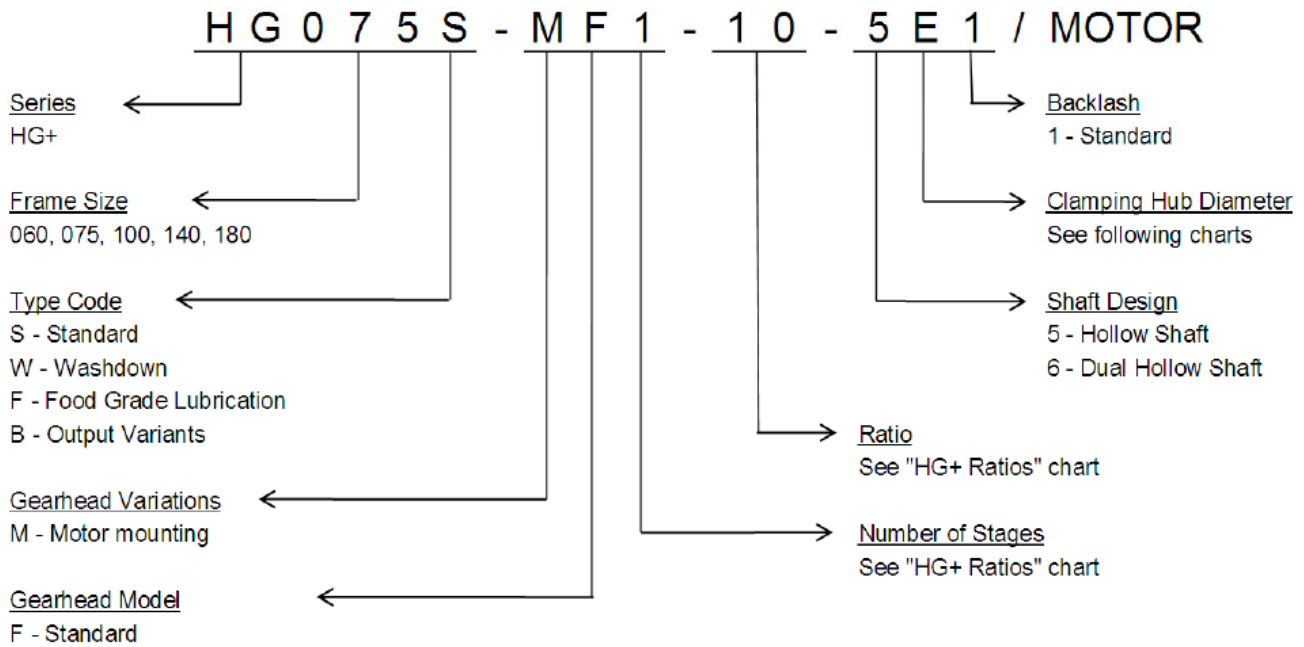

### HG+ Ratios

Stages	1-Stage					2-Stage									
Ratios	3	4	5	7	10	12	16	20	25	28	35	40	50	70	100

### HG+ Clamping Hub Diameters

Frame	B	C	E	G	H	I	K	M	N	O
	11	14	19	24	28	32	38	48	55	60
HG060S-MF1		X	X							
HG060S-MF2	X	X								
HG075S-MF1			X		X					
HG075S-MF2		X	X							
HG100S-MF1					X		X			
HG100S-MF2			X	X						
HG140S-MF1							X			
HG140S-MF2				X			X			
HG180S-MF1								X		
HG180S-MF2							X	X		