



## Power PMAC Demo – Laser Engraving System

### Power PMAC features used in "Laser Power Marker" demo:

#### Multiple Servo Rates - Galvo & normal servo's controlled under "one roof":

A controller performs a series of calculations in order to control position or velocity of any closed loop actuator. These calculations are called servo calculations and based upon the characteristics of the system, they must occur at different rates to achieve optimal performance. The faster a system needs to respond, the higher the servo rate required. Different components in a system may require different servo rates because of their response time characteristic or bandwidth.

Conventional controllers have one servo rate which is applied to all actuators regardless of their bandwidth. It is the user's responsibility to find a servo rate at which most of the actuators have an acceptable performance. Sometimes this is difficult to achieve because of diverse system requirements.

In previous solutions from Delta Tau it was possible to "skip" servo clocks in order to accommodate axes with low bandwidth (sluggish systems). So what's new in Power PMAC? With Power PMAC not only can you slow down servo rates for low bandwidth axes, you can also raise the servo rate for high bandwidth, high performance axes.

In the "Laser Power Marker" demo, the galvanometers used to steer the laser beam are closed at 16 kHz, the voice coil used to focus the beam is closed at 4 kHz, and the index table and loader are closed at 1 kHz. Power PMAC is able to close each axis at individual servo rates ranging from 1 kHz to 120 kHz.

### New features in kinematics:

Power PMAC can perform independent kinematic and inverse kinematic calculations for each coordinate system. This is nothing new if you have been using the Turbo PMAC's kinematic features. What makes Power PMAC superior are the new unique features like:

Real time reporting of axis position/velocity compared to joint position/velocity. This not only eliminates the need for PLC code calculating these values, but also improves data accuracy by completing these calculations within the same servo cycle (no servo cycle delay in reported data).

Kinematic support for PVT (Position-Velocity-Time) moves in addition to Linear and Circular moves. This is very important for users who not only want to take advantage of PMAC's kinematics capabilities, but also want to follow a specific path or pattern defined in PVT mode.

With the "Laser Power Marker" demo, kinematic routines are being used for two different purposes:

The first is to compensate for the pin cushion effect caused by the geometry of galvanometers. Since all of the trigonometric calculations are done in real time, there is no need for any look-up tables, which by itself eliminates any of the errors caused by the interpolation of data.

The second task is to adjust the focal point of the laser beam. In conventional galvanometer applications this is done through the use of F-theta lenses which are made specifically for a given application and would be placed on the exit side of the galvanometer. F-theta lenses are costly and have a fixed focal length. Using kinematics with an adjustable focal length allows application flexibility and lower cost. This not only provides the ability to adjust the focal length based upon the thickness of the work piece and angle of delivery, but also allows marking on 3D surfaces.

### Power PMAC as a Laser Controller

The characteristics of the laser output which affects the way the part is marked is controlled by the shape and timing of the laser command signal (frequency, pulse width, and wave form). In the "Laser Power Marker" demo, two different types of signals are sent to the CO2 Laser unit:

(1) A tickle pulse is sent to the laser unit when the laser is in standby mode, but an



immediate response is required. This tickle pulse has a lower constant frequency and very low duty cycle, just enough to keep the gas ionized and the laser ready to fire. (2) The PWM signal is used to command and control the actual output of the laser when marking is needed. The duty cycle of the signal relates to the intensity of the laser's output power.

All of these signals are generated by the Power PMAC and gated through an off-board NAND gate circuit.

In contrast to a tickle pulse, which has a constant duty cycle, the duty cycle of the PWM signal is not constant and is related to marking speed. The faster the marking, the higher the duty cycle should be. Power PMAC calculates the speed of the target point during inverse kinematic calculations and adjusts the laser output on-the-fly. This insures a constant contrast marking regardless of change in galvanometer position.

### Taking advantage of Power PMAC's Dual Personality

As you may know, the Power PMAC is in addition to being a sophisticated motion controller, a fully capable PC running a Real Time Linux OS. This means it not only supports Delta Tau's regular script PLC and motion control language, but also supports code written and compiled in "C". With the "Laser Power Marker" a "C" program in the Linux environment is used to read and convert the text entered from the keyboard to a motion program in the GPASCII environment. Since these programs are written in C, the user can take full advantage of all the flexibility and conciseness which this language has to offer. The software on the PC side can access both environments simultaneously.

### Backward compatibility of Power PMAC

All of the components of Delta Tau's existing UMAC systems are supported by Power PMAC. To take advantage of Power PMAC all you have to do is replace the normal UMAC Turbo PMAC CPU with a Power PMAC CPU. In addition to the Turbo UMAC Accessories, there will also be Power PMAC specific accessories available for use in the near future. The ACC-24E3 will be the first of these next generation accessories and will utilize the versatile Gate3. In addition to built-in support for different inputs and outputs, Gate3 will remove the limitations caused by the clock interdependencies of Gate1 and Gate2 generations.

## The Motion Computer that provides the "A to Z" for moving from "A to B"

The Power PMAC shatters the barriers that have traditionally surrounded motion control and general-purpose computing. The "Dual Personality" Power PMAC combines in a single processor:

- Delta Tau's 7th generation motion and machine-control processing platform, the culmination of 25 years experience producing state-of-the-art controllers
- Power PC general-purpose computing engine with Real Time Linux - a true real-time multi-tasking operating system

The Power PMAC is truly the first complete RUGGEDIZED Motion Computer solution, packaged in a "3U" envelope!!!

### Power PMAC - Motion & I/O Control:

The Power PMAC combines Delta Tau's legendary motion and I/O control processing engine, the rugged and flexible UMAC (Universal Motion and Automation Controller) modular control system, and a Power PC processor (32/64 bit architecture, 64 bit hardware floating point processing) - resulting in a Motion Computer with unparalleled performance capabilities.



The modular 3U-format UMAC provides a rugged foundation upon which to build your Power PMAC system. The wide selection of plug-in UMAC accessories allows you to configure your Power PMAC to meet the specific application requirements:

### Motor types supported:

- Brushless (AC/DC)
- DC Brush
- Hydraulic
- Induction
- Piezo
- Stepper (open/closed)

### Position Feedback:

- Quadrature encoders
- Sinusoidal encoders
- Resolvers
- Serial-format encoders
- LVDT's, RVDT's

### I/O:

- Axis Flags : In: Home, Limit +/-, Fault, User Out: Amp Enable, Pos Compare
- Digital - Inputs: 24 to 48 channels (per card), TTL to 24V range
- Digital - Outputs: 24 to 48 channels (per card), TTL to 24V range, 25mA to 600mA
- A/D: 12 bit, 16 channels (per card) 16 bit, 4 channels (per card)

### Hi-End Features:

- Synchronized control of as many as 256 axes
- Real Time Linux
- 64-bit hardware floating point motor calculations
- 'S-curve' acceleration with independent accel/decel profiles & 'Jerk' control
- Block execution rate to 5K
- Coordinate rotation & translation with forward & inverse kinematics
- "Open Servo" - write your own loops in 'C'
- Real-time reporting of 'user unit' axis data
- 3D compensation tables
- Script debugger includes breakpoints, cycle count & single-step
- Create PLC's & IEC 1131 with embedded motion & subroutines
- Vector and 2D matrix operations

### Power PMAC - a Real Time Linux Motion Computer:

The Power PMAC is based on the latest generation of embedded Power PC processors, which are renowned for high speed and low power consumption. The embedded Real Time Linux operating system provides for a robust and deterministic operating environment. To complete the 'computer package' the Power PMAC supports typical computer peripherals such as a hard disk drive, display unit (CRT), keyboard, and mouse/pointing device.

The Integrated Development Environment (IDE) provides for seamless C/ C++ application development. Syntax colorization and data structure index is provided via the Intellisense database. Public domain GNU C/C++ cross-compiler is included.

### Hardware:

- 800 MHz to 1 GHz operating frequencies
- Full 32/64-bit architecture
- 64-bit Floating Point Processor
- Support for very large memory
  - 512 MB - 2 GB DDRAM plug-in active memory with error correction
  - 64 MB NOR Flash for standard firmware
  - 512 MB built-in NAND flash for user code/settings
  - USB Flash Stick and SD Card support
- Communications: USB 2.0, Ethernet (100-T, 1000-T), RS-232, PCI Express for video display (x1 & x4), SATA (Hard Drive Port)

### Operating System & Software:

- Complete RT Linux Operating System
- Windows™ based Integrated Development Environment (IDE)
- Integrated GNU C/C++ cross-compiler
- Advanced Built-in Editor/Debugger
- Integrated Intellisense, Syntax Colorization & Code Snippets
- Embedded Web Server - connect to the Power PMAC from anywhere
  - Protocols: HTTP and FTP
- Auto generate C code via:
  - Ladder Logic (IEC-1131) graphical programming for PLCs
- Complete File Management System
- Built-in library of ActiveX Components
- Co-Resident additional software: IEC1131, EPICS, N.C., and a variety of applications like EtheCAT, Cad-COM, etc...



## Power PMAC Technology Breakthroughs

With the creation of **Power PMAC - the "Motion Computer"** Delta Tau has re-defined the traditional relationship between the general purpose computer and accessory / peripheral motion controllers. To facilitate this revolutionary change Delta Tau has developed new technologies, new architectures, and new perspectives.

- **DSPGATE3 ASIC**
- **Embedded Power PMAC**
- **PCIe Power PMAC**
- **Soft Power PMAC**

### DSPGATE3 ASIC

Since 1985 Delta Tau has been an industry leader in the development and integration of ASIC technology. To maximize the power, throughput, and flexibility of the **Power PMAC** we are proud to announce the development of our next generation ASIC - **DSPGATE3**. Built upon the feature set of its predecessors, the new ASIC provides significant new capabilities and performance enhancements including:

- **Built-in resolver excitation generator**
- **Multiple serial encoder protocols supported:**  
SSI/BISS SPI Endat Tamagawa  
Yaskawa Hyperface Panasonic Kawasaki
- **Multiple PWM frequencies on a single ASIC**
- **32-node MACRO interface:**  
MACRO @ 125 Mbps  
MACRO2 @ 1.25 Gbps

The **DSPGATE3 ASIC** has been incorporated into a new axis interface card, the **ACC-24E3**. In order to take full advantage of the powerful new capabilities of the DSPGATE3 the **ACC-24E3** incorporates a new 'mezzanine' design that provides the machine designer with maximum flexibility for both inputs (feedback) and outputs (command). The **ACC-24E3** mezzanine system allows great cost and space savings by reducing the number of 3U interface modules, thus reducing the size of the UMAC rack. Even as size & cost are reduced, performance is significantly enhanced with the use of the **DSPGATE3**. As shown in the diagram on the right, the **ACC-24E3** mezzanine system includes both analog and digital interfaces.

### Power PMAC PCIe Ultra-Lite

A natural derivative of the Power PMAC as the Power PC processor has several built-in PCI ports. High performance in a 1/2 size PCIe footprint for Ethernet motion networks like MACRO, EtherCAT, RTEX, etc...

### Embedded Power PMAC

With the Power GEO Brick you get 'the whole enchilada' in one convenient package; Real Time Linux computer, Power PMAC motion controller with DSPGATE3, & integrated IGBT amplifiers for 4, 6, or 8 axes. The embedded Power PMAC is truly the control system of the future!

### Soft Power PMAC

One of the primary Power PMAC development efforts was to 'port' the present PMAC code from assembly language to 'C' and have it run under Real Time Linux RTOS. Having accomplished this, the next step was to simply run the same code with a RTOS or Real Time Kernel (e.g. InTime™ or VenturComm™ for MS Windows™). The **Soft Power PMAC** offers one additional capability, it can be used as a simulator for application development (no controller installed).

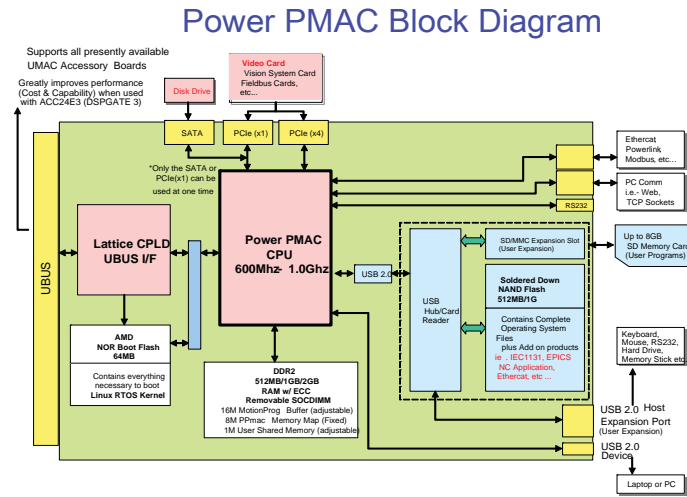

- **Built-in sin/cosine encoder resolver 16 bit interpolator**
- **12 bit hardware 1/T interpolator for servo, capture, compare**
- **Whole-count & fractional encoder count info in a single register**
- **MLDT timer frequency of 600 MHz**
- **PWM counter frequency of 300 MHz**
- **Pulse-frequency output: Pulse/Direction or quadrature**
- **4-phase PWM output for each axis (for steppers)**

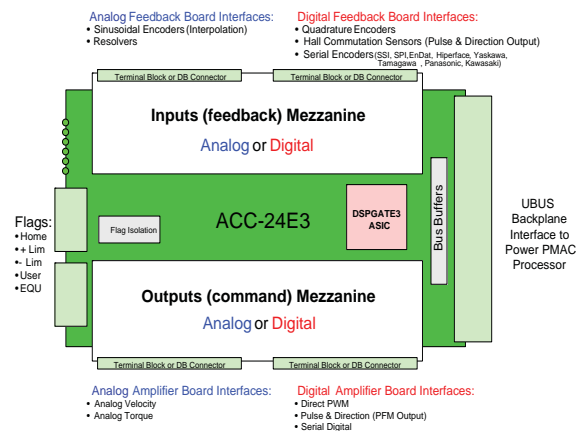

## Power PMAC- the Motion Computer Frequently Asked Questions

### Existing Delta Tau Users

#### Q1) What are the 5 best things about the Power PMAC?

- A1)** It will vary based on your application requirements, but:
- Speed - many operations execute over 10 times faster
  - Precision - 64-bit floating point math for all motor calculations
  - Advanced Program Editor for Motion programs and PLC's Variables:
  - 'Named' variables supported
  - Self-documenting Data Structures replace 'l-variables'
  - Web connectivity - no 3rd party software required

#### Q2) Can I upgrade my Turbo UMAC controller to the Power PMAC?

- A2)** Yes, all you have to do is to replace your Turbo CPU card with the Power PMAC CPU card. All of the UMAC components in the UMAC system are compatible with the Power PMAC.

#### Q3) Are my Turbo PMAC programs (motion & PLC) compatible with the Power PMAC?

- A3)** Some modification is required, but as the program structures are fundamentally the same, it is a straightforward replacement.

#### Q4) What tools & utilities are available for the Power PMAC?

- A4)** The Power PMAC IDE includes the same type of tools (Terminal Window, Watch Window, Tuning & Plotting, Backup & Restore, etc...) that are currently in the PEWIN Pro2 Suite. For Power PMAC these tools are 'net' components and can easily be integrated into the user's application.

#### Q5) What is an IDE (Integrated Development Environment)?

- A5)** An application/environment that is used by computer programmers to develop software. An IDE generally includes; source code editor, a compiler/interpreter, build automation tools, and a debugger.

#### Q6) What software & tools are included with the Power PMAC?

- A6)** Power PMAC's embedded web server includes:
- Data Displays: Position, Status, Watch Window (variables)
  - Terminal Window for direct communication
  - Basic program Editor / Downloader
  - Backup & Restore (controller settings & programs)

### General Computing & New PMAC Users

#### Q1) Is the Power PMAC a ready to go "Linux PC"?

- A1)** Yes - plug your mouse & keyboard into the USB ports, the monitor into a PCIe video card, & hard drive into the SATA port and you are good to go!

#### Q2) Does Power PMAC's Linux Real Time OS support standard open-source applications?

- A2)** Yes, supported applications/environments include: OpenOffice, Apache, GNOME, MySQL, Gimp, Inkscape, etc ...

#### Q3) How do we setup the Power PMAC & the machine?

- A3)** The Power PMAC includes powerful yet easy to use software for machine setup including; motor phasing & tuning, position & status, backup & restore, I/O control and status.

#### Q4) Does Power PMAC support 'remote' connection via the internet?

- A4)** Yes, it has a built-in web server which supports FTP & HTTP.

#### Q5) What else do I need to develop my machine control programs and GUI (Graphical User Interface)?

- A5)** Everything you need is included in the Power PMAC IDE: Scripting language for synchronous motion programs  
PLC's can be written in C/C+ or scripting language  
Data Structures for hardware and software registers  
API for Power PMAC function calls  
C# library ("User Control Objects") for GUI development

#### Q6) Can I write my own servo algorithms?

- A6)** Yes, you can write your custom algorithms directly in 'C'.

#### Q7) We are machine builders (not C programmers); is the Power PMAC a good fit for us?

- A7)** Absolutely - PMACs have always included a script language for programming motion and sequencing machine operations (PLC). Our script language auto-pipelines moves, and now it includes more powerful debugging & diagnostic tools. For CNC applications the Power PMAC can directly execute G-codes (no pre-processing required).