

# *Servo Tube*

DIN EN ISO 9001:2008



*Series ST*

# Tubular Motor Technology

## Motor Technology

Comprising just two parts, a rod and forcer, the tubular linear motor is inherently simple and elegant. The stainless steel rod is filled with rare-earth magnets placed end to end. The forcer incorporates a series of coils connected as three phase windings. When the coils are excited by a three phase current, a magnetic field is created which interacts with the rod magnetic field, generating linear force.

In the linear motor configuration, the rod is held fast, while the forcer moves. The load is mounted directly to the forcer supported by a bearing rail. If the forcer is held fast, the rod moves in actuator mode. The load is connected to the rod, which is supported by a long-life, internal dry bearing.

## Tubular Motor Advantages

There are essentially three types of linear motor: flat-bed, U-channel and tubular. The flat-bed delivers high force but suffers from cogging. In addition, magnetic attraction between the forcer and magnet track opposes motion. The U-channel is thermally inefficient as the heat generating coils are enclosed in magnets. The tubular motor eliminates these issues. Magnetic forces are balanced and motion is smooth and cogging-free. The forcer coils have a built-in heatsink and wrap around the magnets for optimal heat dissipation as well as the most effective use of magnetic field.

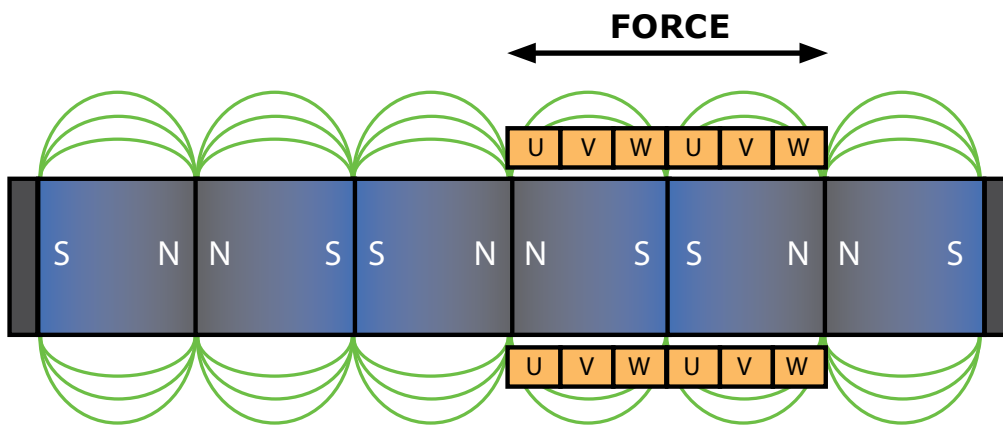

## Built-In Feedback

Traditional linear motors require a costly linear encoder necessitating careful alignment during installation. Due to the sinusoidally varying magnetic field of the ServoTube linear motor, Hall sensors in the forcer can provide position information with repeatability of 12 microns. The linear encoder is eliminated. Position output is standard analog sin/cos encoder signals. Some ServoTube versions generate quadrature incremental encoder signals with digital Halls - a universal interface to all drives and controllers.

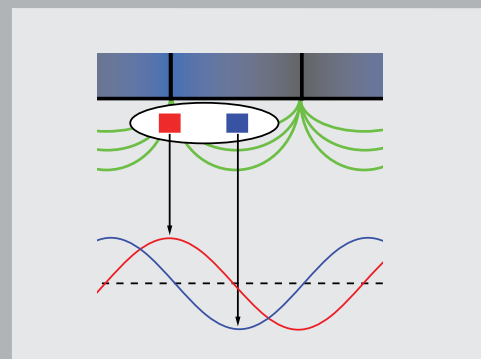

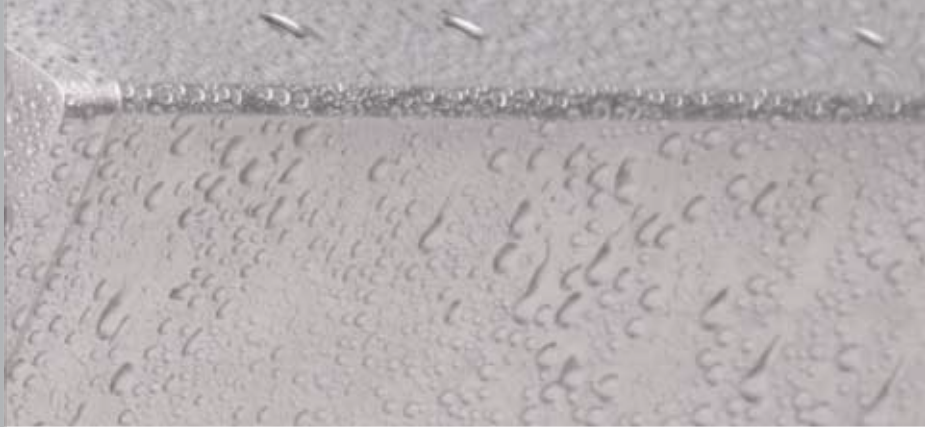

## Rugged, Sealed & Submersible

Flat-bed and U-channel motors with exposed magnet tracks and fragile linear encoders require protection in some industrial environments. ServoTube, with sealed components and built-in feedback is rugged and IP67 rated. The air gap between rod and forcer is non-critical. Installation is simple and cost of ownership low. For the harshest environments a water-cooled, stainless steel version, Hygienic ServoTube, is available rated at IP69K. Hygienic Servotube also meets the requirements of IP68 for fully submersible operation.

## Hygienic Application

With smooth surfaces and IP69K high-pressure wash-down rating, Hygienic Servotube is ideal for material handling applications in the food & beverage and pharmaceutical industries. The ruggedness and mechanical elegance of Hygienic ServoTube can bring significant cost savings to sterile environment applications.

## Water Cooling

Water cooling approximately doubles the actuator continuous force rating. The stainless steel waterways inside the forcer require no special coolant - ordinary water can be used. Operating costs are minimal and there is no environmental impact.



## 316 Stainless Steel

Free from contaminant-gathering recesses, the smooth stainless steel housing of the Hygienic Servotube delivers high resistance to corrosion and chemical attack.

## IP69K High-Pressure Wash-Down

The IP69K rating defines the highest level of sealing against water ingress, facilitating high-pressure wash-down. High-pressure cleaning techniques use significantly less water and cleansing agents than typical low-pressure hose-down. The cleaning process itself is easier and quicker. High-pressure wash-down reduces cost and is environmentally friendly.



# Direct Electric Drive

Electric drive systems have many advantages over pneumatic solutions. While pneumatics can deliver high speed and ruggedness at low cost, they are best applied in simple bang-bang control applications. When programmable positioning and fast-settling times are specified, pneumatic systems become complex and expensive. In all cases a compressor is required and maintenance costs are high.

Belt drives and ballscrews are the traditional implementations of electric linear drive. The linear motor, with its undisputed performance and maintenance advantages, has typically been limited to high-end applications. This is mainly due to installation issues and the expense of linear encoders. The easy-to-use form factor of the ServoTube tubular motor coupled with highly cost-effective internal feedback now brings the high performance and mechanical simplicity of linear motors to mainstream industrial applications.

## Going Green

Electric drive automation uses just 30% of the energy consumed by a pneumatic system, reducing carbon emissions for a greener environmental profile.

Legislation to limit audible noise is gaining momentum. Direct linear drive significantly reduces noise pollution - a critical factor in many applications, particularly laboratory automation.

Pneumatic systems also generate oil-misting pollution. Electric control eliminates air borne contaminants creating cleaner working conditions.

## Tubular Motor

### Pros

- High speed & acceleration
- Fast settling time
- Inherently rugged
- Maintenance-free
- Low audible noise
- Reduced machine vibration

### Cons

- Limited stroke length

## Ballscrew

### Pros

- High force

### Cons

- Limited speed & acceleration
- Requires lubrication
- Short moves cause wear
- Unsuitable for hygienic applications
- Backlash hysteresis
- High audible noise

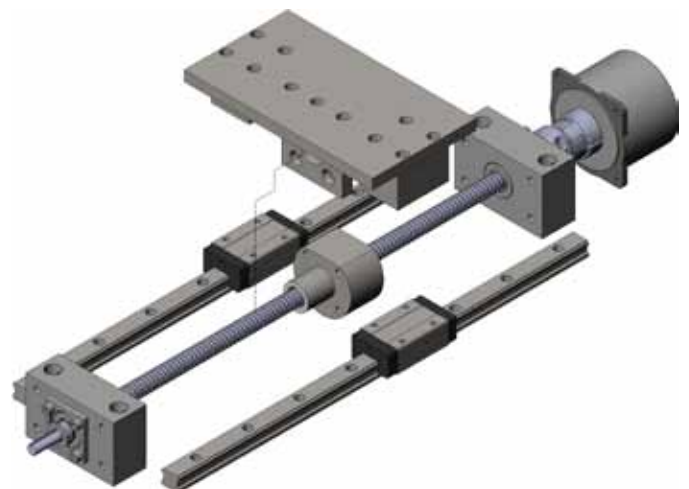
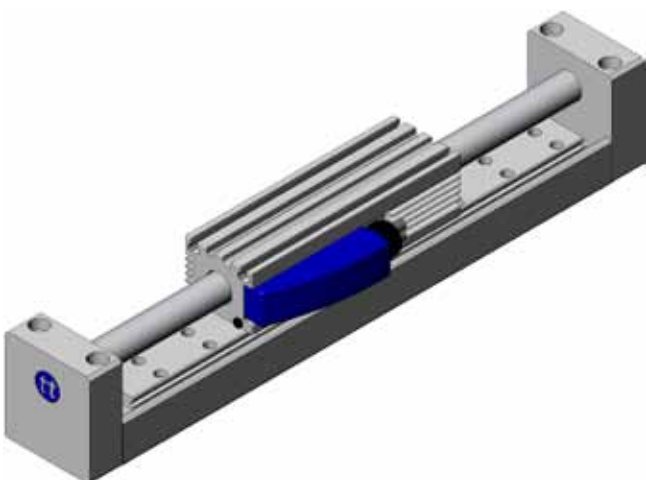



Feature	Tubular Motor	Ballscrew	Belt Drive	Pneumatics
Speed	•••••	••	•••••	••••
Acceleration	•••••	•••	•••••	•••••
Settling Time	•••••	•••	•	•
Force	•••	•••••	•••	•••••
Stroke Length	••	•••	•••••	•••
Installation	•••••	•••	•••	••
Maintenance	•••••	•••	•••	••
Robustness	•••••	•	••	•••••
Audible Noise	•••••	••	••	•
Green Index	•••••	•••	•••••	••
Cost	•••	•••	•••••	•••

## Belt Drive

### Pros

- High speed
- Low cost
- Long stroke

### Cons

- Poor settling time
- Belts wear and need replacing
- Unsuitable for hygienic applications
- High audible noise

## Pneumatics

### Pros

- Lowest cost for bang-bang control
- High speed & acceleration
- Tolerates harsh environments

### Cons

- Requires expensive-to-run compressor
- Closed loop control is complex & expensive
- Poor settling time
- High audible noise
- Requires significant maintenance
- Oil-misting pollution

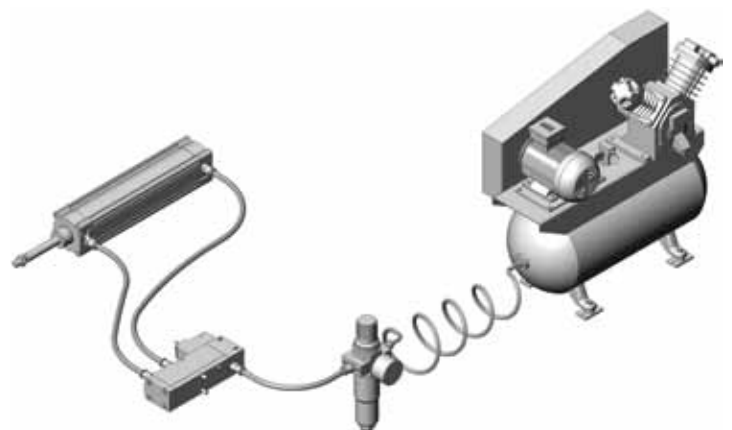
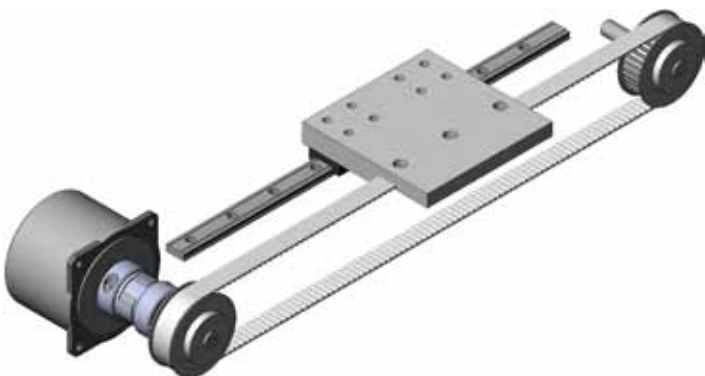



# Using Tubular Motors

Dunkermotoren linear motors and actuators set a new standard for performance and simplicity in linear motion. The form factor of ServoTube enables a high degree of flexibility in mechanical configuration. Moving-rod actuators and moving-forcer linear motors are both easily mounted. Motors can be combined into pick-and-place gantries or integrated into stages with minimal design effort. Linear encoders can be added for higher-precision applications. Load connection is very straightforward. Mount directly to T-slots on the forcer or connect to the rod via industry-standard accessories.

With IP67 rating as standard and IP69K available on hygienic versions, ServoTube can be safely applied in demanding environments. The built-in heatsink eliminates the need for forced-air cooling. For hygienic applications where fins are not permitted, water cooling maximizes the continuous force rating.

Some Servotube actuator models incorporate a brake for a cost-effective, compact solution to power-down parking of vertical axes. 24 VDC operated, the brake provides a holding force of 200 N and is adjustment-free.



## Actuator Mounting

The compact design of ServoTube enables high-density placement of vertical axes. Simply mount the forcer to the machine and connect the load to the rod using a range of industry-standard accessories. The rod glides on lubrication-free, field-replaceable internal bearings rated up to 64,000 km - 10 times the life of a typical ballscrew.

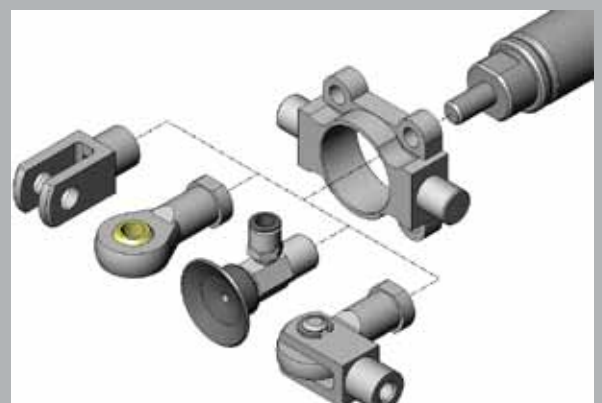

## Motor Mounting

The rod is held in mounting brackets at each end, similar to a ballscrew. The large air gap eliminates the need for precision alignment. For long stroke applications, special brackets can provide an upward tensioning force to reduce the effects of gravity on the rod.

Theforcer can be supported by a single bearing rail underneath or, for a lower profile, a bearing rail on each side. It is possible to run multiple forcers on one rod, which brings great mechanical simplicity to material handling applications such as loaders/unloaders.

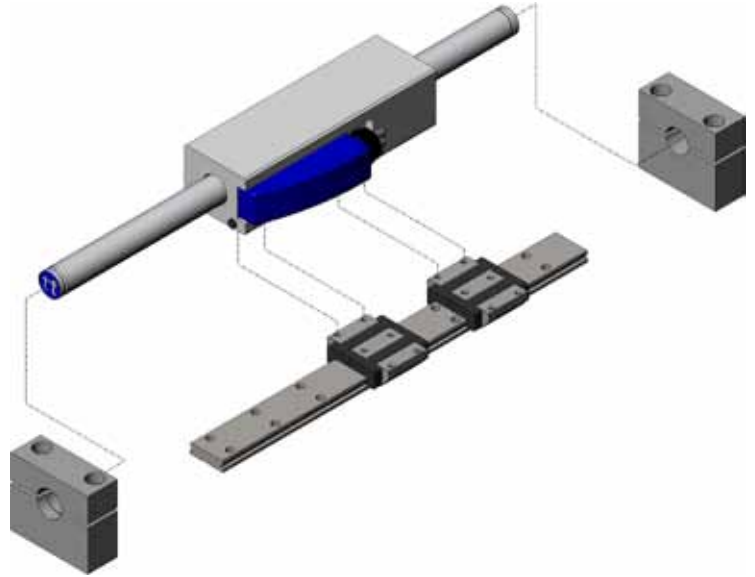

## Building Gantries

After motors are mounted into modules, they can be combined quickly and simply using standard interface hardware to create a variety of multi-axis systems. Only a single interface plate is required to create a customised, fully functional pick-and-place system using a module and high-rigidity actuator. Development time and risk for automation projects are drastically reduced by employing performance-guaranteed building blocks.

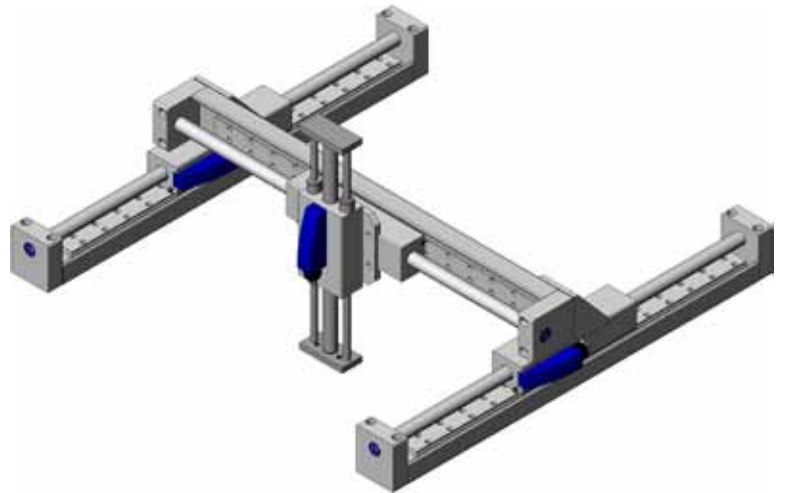

## Making Stages

Tubular motors also find application in high-precision stages. Ironless construction eliminates cogging and hysteresis. The perfectly sinusoidal back EMF facilitates minimal velocity ripple for high-performance scanning applications. Combined with a precision position encoder, sub-micron levels of accuracy and repeatability are readily achievable.

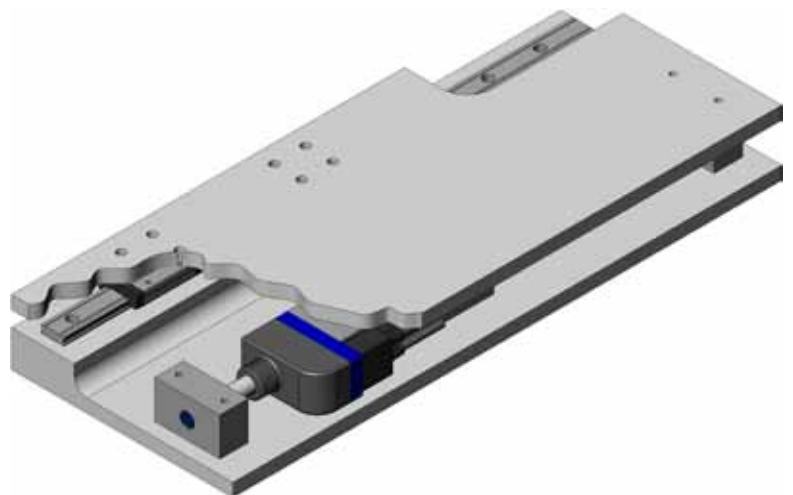

# Application Examples

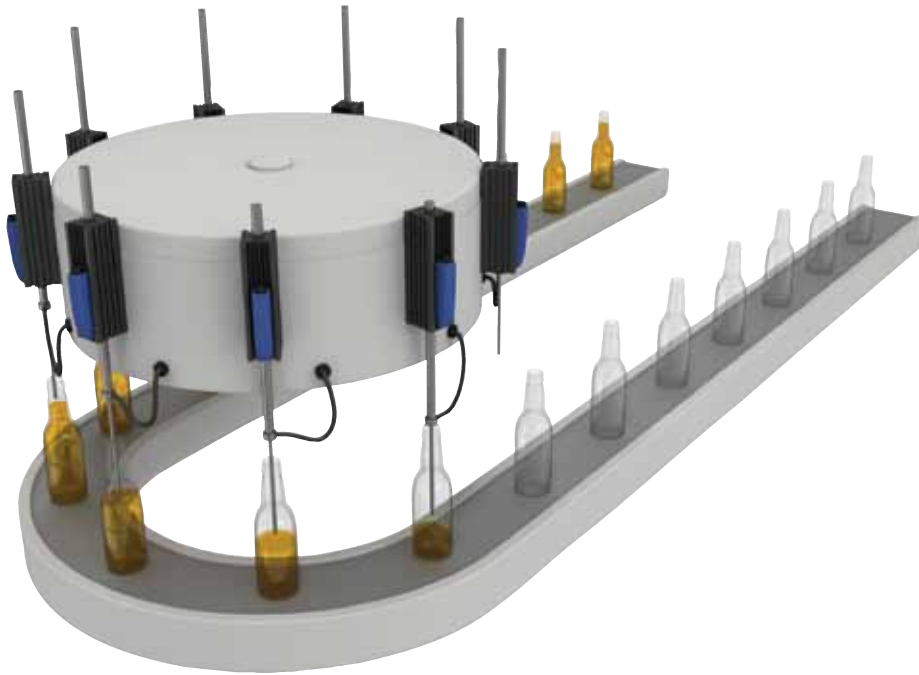

## Bottle Filling

The ServoTube fillers are synchronized with the conveyor and maintain the same feed tube height above the liquid as the bottles fill. An earlier generation machine used cams which required changing for different product runs. The ServoTube implementation both eliminated downtime and significantly increased productivity.

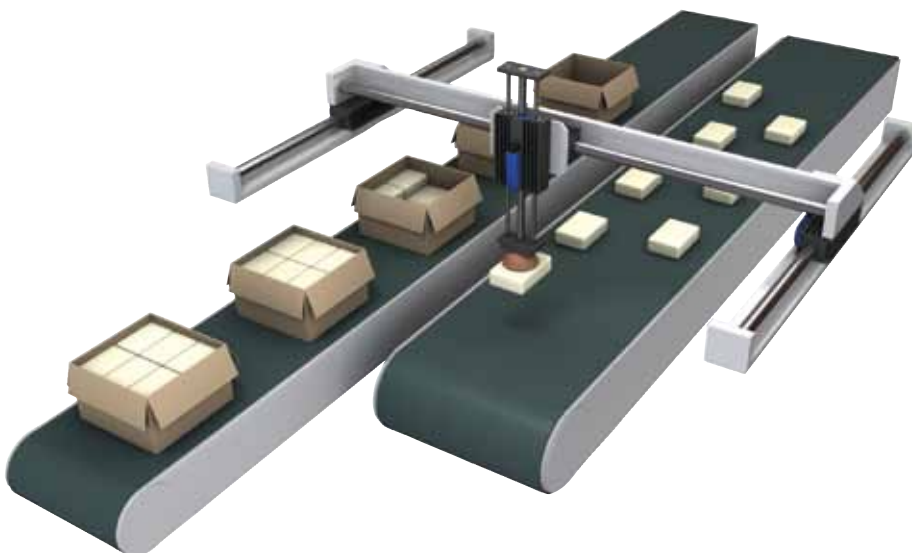

## Carton Packing

Packages on the infeed conveyor are detected by a vision system then stacked into boxes on a second conveyor. The speed and dynamic response of the tubular motor gantry increased productivity by 20% compared with the original ballscrew implementation.



### Conveyor Transfer

The bottles on the infeed conveyor are joined together in pairs. The bottles are separated and trimmed, then placed on a new conveyor with the correct spacing for the next process. The ability to run multiple forcurs on one rod greatly simplified the mechanics of the machine.



### Speed, Reliability, Simplicity

The speed and dynamic response of a tubular linear motor can significantly increase throughput versus a ballscrew. Food-safe internal dry bearings built in to the actuator have a rated lifetime ten times that of a ballscrew. The non-contact construction of the linear motor is maintenance-

free and disperses no lubricants. The direct drive simplicity of ServoTube eliminates couplings, belts, pulleys and gearboxes, minimizing machine footprint. Downtime is eliminated and cost of ownership reduced.

### Packet Handler

The carousel buffers and reorients stacked packages for placement on the conveyor. An older generation machine used a rotary motor in the base of the machine with a belt driving a ballscrew. Direct drive eliminated a significant number of mechanical components and reliability was increased.

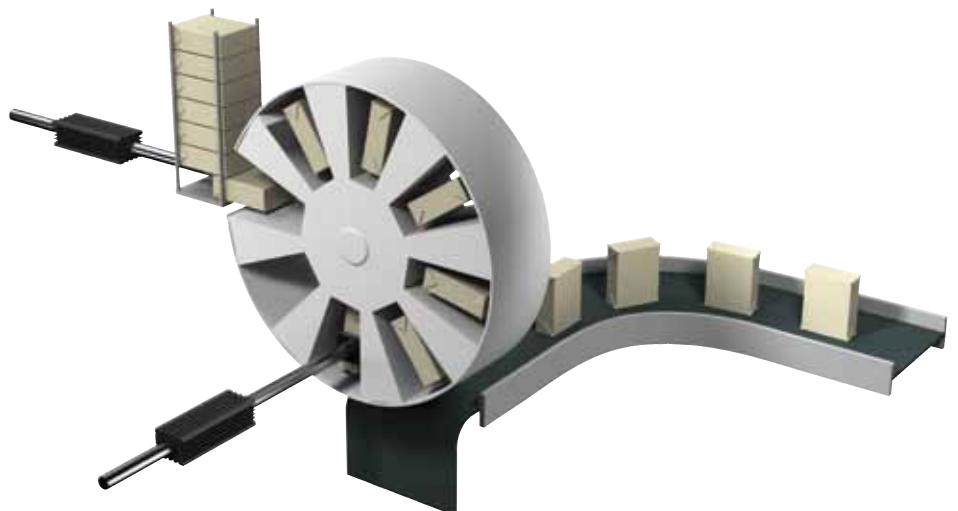

# Product Family Overview

ServoTube is available in three sizes: 11, 25 and 38, indicating the rod diameter in millimeters. Each size category incorporates four forcer coil stack lengths delivering a range of forces. All ServoTube forcers have three phase windings. Position output is sin/cos analog encoder - with the exception of Hygienic ServoTube, which generates incremental encoder and digital Hall signals. Key specifications are expressed in the adjacent table. The blue icon depicts a water cooled version.

## Linear Actuator

ServoTube Actuator is ideal for push/pull/lift material handling applications. An internal dry bearing provides clean, quiet, maintenance-free performance. Life expectancy far exceeds typical ballscrew solutions. The actuator accepts a range of industry-standard accessories for easy mechanical integration.

11 25 38



## Hygienic Actuator

Hygienic ServoTube is a stainless steel, water-cooled version of the 38 actuator. Two models are available operating up to 600V. Position output is incremental encoder with digital Halls, enabling the motor to be used with any drive. Resolution is 10 micron with up to 25 micron repeatability.

38



## Linear Motor

The ServoTube linear motor is an ideal solution for easy integration into pick-and-place gantries and material handling machines. The large air gap eliminates the need for precision alignment and simplifies installation. The load conveniently mounts directly to T-slots on the forcer.

11 25 38



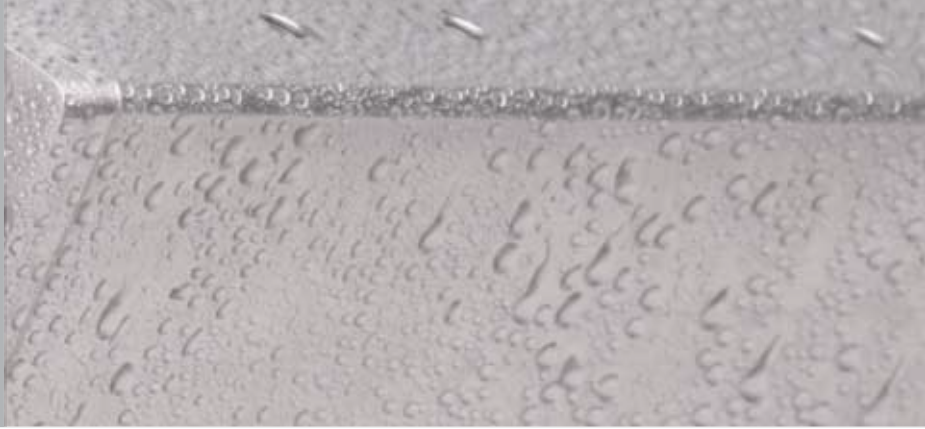

		11	25	38	38
Peak Force	N	46-92	312-780	744-1860	744-1860
Continuous Force	N	6-19	51-103	137-276	217-458
Maximum Velocity	m/s	5.6	8.7	6.2	4.7
Winding Rating	V	90	300	300	600
Forcer W x H	mm	28x61	95x54	122x70	108x72

## High-Rigidity Actuator

A high-rigidity actuator is available with integrated outrigger bearings for applications with higher side loading. Ball bushings with steel bearing rails provide maximum support. Polymer bushings with aluminum rails are also available for weight-critical vertical axes. Twelve stroke lengths are available from 28-310 mm.

25



## Motor Modules & Gantries

ServoTube modules are complete and ready to use, providing a quick route to integrating linear motor performance into conventional machine designs. Module subsystems are equipped with long-life single bearing rail, limit switches and drag-chain. Laser-welded bellows and hard-anodizing are optional. For applications requiring higher levels of accuracy, a fully integrated optical encoder option delivers micron resolution.

11 25 38



Consult factory for custom modules & gantries.

## Germany

Sachsen-Anhalt Nord, Berlin, Brandenburg

**Dunkermotoren GmbH**  
Allmendstraße 11 · 79848 Bonndorf  
Tel. (07703) 930-0 · Fax -210/212  
www.dunkermotoren.com  
info@dunkermotoren.de

Niedersachsen, Hessen Nord, Westfalen Ost

**Ingenieurbüro Heinrich Jürgens**  
Roggenhof 5 · 31787 Hameln  
Tel. (05158) 980-98 · Fax 99  
ingenieurbuero.juergens@real-net.de

Hamburg/Bremen, Schleswig-Holstein,

Niedersachsen Nord, Mecklenburg Vorpommern  
**Technisches Büro Kühling/Merten**  
Redder 1 B · 22393 Hamburg  
Tel. (040) 5234098 · Fax (040) 5282476  
www.kuehling-merten.de · km@kuehling-merten.de

Ruhrgebiet

**Lothar Amborn**  
Fasanenstrasse 21b · 45134 Essen-Stadtwald  
Tel. (0201) 4435-00 · Fax 01  
lothar.amborn@t-online.de

Rheinland

**ATS Antriebstechnik Schlotte**  
Reisertstrasse 10 · 53773 Hennef  
Tel. (02242) 90415-90 · Fax -99  
o.schlote@antriebstechnik-nrw.de

Hessen

**Antriebstechnik Eberhardt GmbH**  
Landgrabenstrasse 21 · 61118 Bad Vilbel  
Tel. (06101) 98168-0 · Fax -10  
www.antriebstechniken.de/eberhardt  
info@ategmbh.de

Bayern Nord

**Christleven Elektrotechnik GmbH**  
**Office Bayreuth**  
Preuschwitzer Str. 36 · 95445 Bayreuth  
Tel. (0921) 15 11 788-0 · Fax (0921) 15 11 788-88  
www.christleven.de · info@christleven.de

Sachsen, Thüringen,  
Sachsen-Anhalt Süd

**Christleven Elektrotechnik GmbH**  
**Office Chemnitz**  
Herrmannstr. 28a · 04741 Roßwein  
Tel. (03432) 27 99 239 · Fax (0921) 15 11 788-88  
www.christleven.de · info@christleven.de

Bayern Süd

**Christleven Elektrotechnik GmbH**  
**Office München**  
Faustnerweg 10 · 81479 München  
Tel. (089) 72 77 97 97 · Fax (0921) 15 11 788-88  
www.christleven.de · info@christleven.de

Württemberg

**Technisches Büro Späth**  
Dornierstrasse 4 · 71069 Sindelfingen-Darmsheim  
Tel. (07031) 794 34-60 · Fax -70  
www.spaeth-technik.de · tb.spaeth@t-online.de

Nordbaden, Rheinland-Pfalz, Saarland

**Dunkermotoren GmbH**  
Andreas Rau  
Postfach 11 11 13 · 76061 Karlsruhe  
Tel. (0721) 830 1021 · Fax (0721) 830 1035  
andreas.rau@dunkermotoren.com

Südbaden

**Dunkermotoren GmbH**  
Allmendstrasse 11 · 79848 Bonndorf  
Tel. (07703) 930-0 · Fax (07703) 930-210  
info@dunkermotoren.com

## Europe and Overseas

Austria

**Dunkermotoren**  
Armin Keller - Sales Representative Austria  
Tel. +43 7250 80 230 · Fax +43 7250 671  
armin.keller@dunkermotoren.com

Belgium / Luxembourg

**Elmeq B.V.B.A.**  
Industrial Zone Beveren-Noord  
Onledegoedstraat 79 · 8800 Roeselare  
Tel. +32 51 25 98-11 · Fax -18  
www.elmeq.be · info@elmeq.be

China

**East China - Dunkermotoren (Taicang) Co.,Ltd**  
No. 9 Factory Premises · 111 North · Dongting Road  
Taicang Economy Development Area  
Taicang 215400, Jiangsu Province  
Tel: +86 512-8889 8889-101 · Fax: +86 512-8889 8890  
Email: sales.cn@dunkermotoren.com

**South China - Dunkermotoren (Taicang) Co.,Ltd.**

Guangzhou Representative Office · Room 3906,  
39 floor, block B, Fuli Jinxi Business Center  
No 5 Fuchang Lu, Haizhu District, Guangzhou City,  
Guangdong Province  
Tel: +86 20-8920 9413 · Fax: +86 20-8920 9411  
Email: sales.cn@dunkermotoren.com

**North China - Dunkermotoren (Taicang) Co.,Ltd.**

Beijing Representative Office · No.916 Room,  
Thirsty Building ,2 South 3rd Ring Road,  
Chaoyang District, Beijing City, P.R. China 100022  
Tel: +86 10 6568 5852 · Fax: +86 10 6568 5853  
Email: sales.cn@dunkermotoren.com

**West China - Dunkermotoren (Taicang) Co.,Ltd.**

Chongqing Representative Office · Room 25-2,  
D Building, Wanda Piazza Commercial Apartment, No.8  
Jiangnan Road NanAn District Chongqing  
Tel: +86 23-6280 0974 · Fax: +86 23-6280 0974  
Email: sales.cn@dunkermotoren.com

Czech Republic

**Schmachtl CZ s.r.o.**  
Vestec 185 · 25242 Jesenice  
Tel. +42 02 44 00 15 00 · Fax +42 02 44 91 07 00  
www.schmachtl.cz · office@schmachtl.cz

Denmark

**DJ Stork Drives** - a branch of DJ Stork Drives AB  
Korskildelund 6 · 2670 Greve  
Tel. +45 3691 5251 · Fax. +46 8 635 60-01  
www.storkdrives.dk · per.nielsen@storkdrives.dk

Finland

**Wexon OY**  
Juhaniantie 4 · 01740 Vantaa  
Tel. +358 9 290 440 · Fax +358 9 290 44100  
www.wexon.fi · wexon@wexon.com

France

**Dunkermotoren France S.A.S.**  
Actipôle de La Fonderie · Bâtiment le Cobalt  
470 Route du Tilleul · 69270 Cailloux sur Fontaines  
Tél: +33 633 804 410  
sales.fr@dunkermotoren.com

Great Britain

**Dunkermotoren UK Ltd.**  
Kingfisher House · Suite 2 · Rownhams Lane  
North Baddesley · Southampton · Hants · SO52 9LP  
Tel. +44 23807 33509 · Fax +44 23807 34237  
sales.uk@dunkermotoren.com  
Email: peter-lawton@dunkermotoren.com

Italy

**Dunkermotoren Italia s.r.l.**  
Corso Sempione, 221 · I-20025 Legnano MI  
Tel. +39 0331-596165 · Fax +39 0331-455086  
sales.it@dunkermotoren.com

Korea

**Dunkermotoren Korea Ltd.**  
Parkview 19th, 1908-Ho, #6, Jeongja-dong,  
Bundang-gu, Seongnam-si, Gyeonggi-do, 463-863  
Tel. +82 31 719 0033 · Fax +82 31 719 0134  
junghoon.myoung@dunkermotoren.com

Netherlands

**ERIKS Aandrijftechniek bv**  
Broeikweg 25 · 2871 RM Schoonhoven  
Tel. +31 182 30 34 56 · Fax +31 182 38 69 20  
www.eriks-at.nl · info.schoonhoven@eriks-at.nl

Norway

**DJ Stork Drives** - a branch of DJ Stork Drives AB  
Storgata 15 · NO-2750 Gran  
Tel. +47 6160 9492 · Fax. +47 6717 6401  
www.storkdrives.no · arve.stensrud@storkdrives.no

Poland

**PPH. Wobit E.K.J. Ober S.C.**  
UL. Gruszkowa 4  
61-474 Poznan  
Tel. +48 61 8350-800 · Fax -704  
www.wobit.com.pl · wobit@wobit.com.pl

Slovakia

**Schmachtl SK, s.r.o.**  
Valchárska 3 · 82109 Bratislava  
Tel. +421 2 582756-00 · Fax -01  
www.schmachtl.sk · office@schmachtl.sk

Spain

**Elmeq S.L.**  
(Gran Via Center) · C/Vilamari 50, 3° A y B  
08015 Barcelona  
Tel. +34 93 422 70 33 · Fax +34 93 432 36 60  
www.elmeq.es · contacto@elmeq.es

Sweden

**DJ Stork Drives AB**  
Box 1158 · Strandväg 116  
SE-171 54 Solna  
Tel. +46 8 635 60-00 · Fax -01  
www.storkdrives.se · info@storkdrives.se

Switzerland

**Dunkermotoren**  
Rolf Leitner - Sales Representative Switzerland  
Tel. +41 44 799 17-71 · Fax-75  
rolf.leitner@dunkermotoren.com

Turkey

**Femsan**  
Harmandere Mah. Tasocak  
Yolu No.8 · 81520 Kurtkoy – Pendik · Istanbul  
Tel. +90 216 482 48 44 · Fax +90 216 482 50 52  
www.femsan.com · info@femsan.com

United States of America

**Dunkermotoren USA Inc.**  
**Headquarters**  
2511 Technology Drive, Suite #105  
Elgin, IL 60124  
Tel. +1 224 293 1300 · Fax +1 224 293 1301  
www.dunkermotor.com · info@dunkermotor.com

**US Mid West and South East regions**

2511 Technology Drive, Suite #105  
Elgin, IL 60124  
Tel. +1 224 293 1300 · Fax +1 224 293 1301  
www.dunkermotor.com · info@dunkermotor.com

**US North East region**

18 Columbine Lane  
Kings Park, NY 11754  
Tel. +1 631 724 1701 · www.dunkermotor.com  
Kenneth.Remis@dunkermotoren.com

**US West Coast region**

2715W 180th Street  
Torrance, CA 90504  
Tel. +1 310 323 1996 · www.dunkermotor.com  
Dee.Chatterjee@dunkermotoren.com

Production: Dunkermotoren Linear Systems Ltd.

Wollaston Way · Basildon, SS13 1DJ · UK

www.dunkermotoren.de/Linear · Tel. +44 1268 287070 · Fax +44 1268 928372

Dunkermotoren GmbH

Allmendstraße 11 · D-79848 Bonndorf/Schwarzwald

www.dunkermotoren.com · info@dunkermotoren.de · Tel. +49 7703 930-0 · Fax +49 7703 930-210/212