

# Servo Speed Reducers

**onvio**



## PRECISE

- Low Backlash
- High Shock Load Capacity
- Exceptional Torsional Stiffness
- Rigid Bearing Construction
- Smooth, Quiet Operation

## INTELLIGENT

- Slotted Interface Offers Quickest, Easiest Installation to Any Servo Motor
- Interchangeable Modules Allow for Flexible Ratio Adaptation
- Highest Degree of Exchangeability with Other Reducers
- Add a Right Angle or Belt Stage With Four Bolts!

## DYNAMIC

- Hardened, Ground Gears
- Low Inertia
- High Safety Factor
- Input Speeds to 6000 rpm
- Finned Aluminum Housing Dissipates Motor Heat and Enhances Motor Performance



## PRECISE,

## INTELLIGENT,

## DYNAMIC

Today's servo motors have been designed to provide higher torque and greater dynamic performance to a growing number of industries and applications. Consequently, the demands on the gearbox have become equally as challenging. Dynamic performance, backlash and torsional stiffness are all crucial to the system.

Onvio's revolutionary, modular approach to gearbox design has resulted in three unique families of products that offer the right performance and value for any application. The modular concept allows Onvio to provide complete OEM solutions quickly and economically. Whether your application requires a custom housing, special finish, integrated servo motor or a completely custom gearbox, let Onvio's team of engineers work for you.

**onvio**

# Onvio Speed Reducers

## Servo-Ready By Design

### Choose from Three Reducer Product Families

## AP

### Highest Performance

In applications that demand the greatest positioning accuracy, highest torsional stiffness, and lowest backlash, Onvio's authentic planetary, AP, with its compact axial design, is the correct choice.

- Precision, hardened, ground gears insure backlash down to 3 arc minutes
- High torsional stiffness
- Single and two stage construction for a wide range of standard ratios
- Short, compact design

## HP

### Greatest Flexibility

For applications requiring low inertia and low backlash for speed control and precise positioning, Onvio offers the hybrid planetary, HP, design.

- 5:1 hardened ground planetary gear output stage guarantees backlash down to 5 arc minutes
- Patented one-piece spur gear cartridge
- Unique o-ring seals allow for smooth, quiet operation at any speed
- Modular design offers quickest delivery of all standard ratios

## AL

### Best Value

Designed for use in the emerging market of low cost servo motors, Onvio has developed an economical, precision planetary gearbox, the AL series.

- One-piece, steel construction
- Precision planetary gears provide backlash of 12 arc minutes
- Grease filled, maintenance free
- Metric, round body design
- NE series offers NEMA input and output designs
- 20,000 hour life

# AP

## AP Speed Reducers

### Highest Performance

Onvio's authentic planetary, AP, provides designers with the greatest positioning accuracy and highest torsional stiffness, along with the lowest backlash gearbox available. The AP design incorporates single or two stages of planetary gearing to create five frames sizes with rated torque from 40 Nm up to 900 Nm.

Standard backlash is 5 - 8 arc minutes and reduced backlash is 3 - 5 arc minutes, so designers can choose the appropriate level of precision for each application.

Available in twelve standard ratios from 4:1 to 90:1 with optional ratios upon request.

With a two-piece modular design, Onvio's AP gearbox can be customized to meet your OEM requirements.

- Custom housing designs
- Washdown environments
- Integrated servo motor design
- Various lengths of output shafts
- Wide range of operating temperatures

*Select Onvio's AP gearbox when low backlash and dynamic response are critical.*

#### Modular High Tech Design

Modularity and flexible design offer an advanced technology reducer that can be universally mounted

#### High Torsional Stiffness

Contact of three planetary gears in the steel crown gear along with a large diameter output, provide outstanding rigidity

#### High Capacity Output Bearings

Two output bearings, located forward in the gearbox result in higher bearing capacity and longer bearing life

#### Low Backlash

Hardened, ground gears guarantee low backlash - down to 3 arc minutes

#### Universal Servo Interface

Flexible slotted bolt circle and oversized pilot allow for easy motor installation and no adapters

Floating pilot and high capacity input bearings guarantee alignment between motor and gearbox

#### Cool Operation

Unique fins dissipate heat from servo motor and helps to lighten gearbox

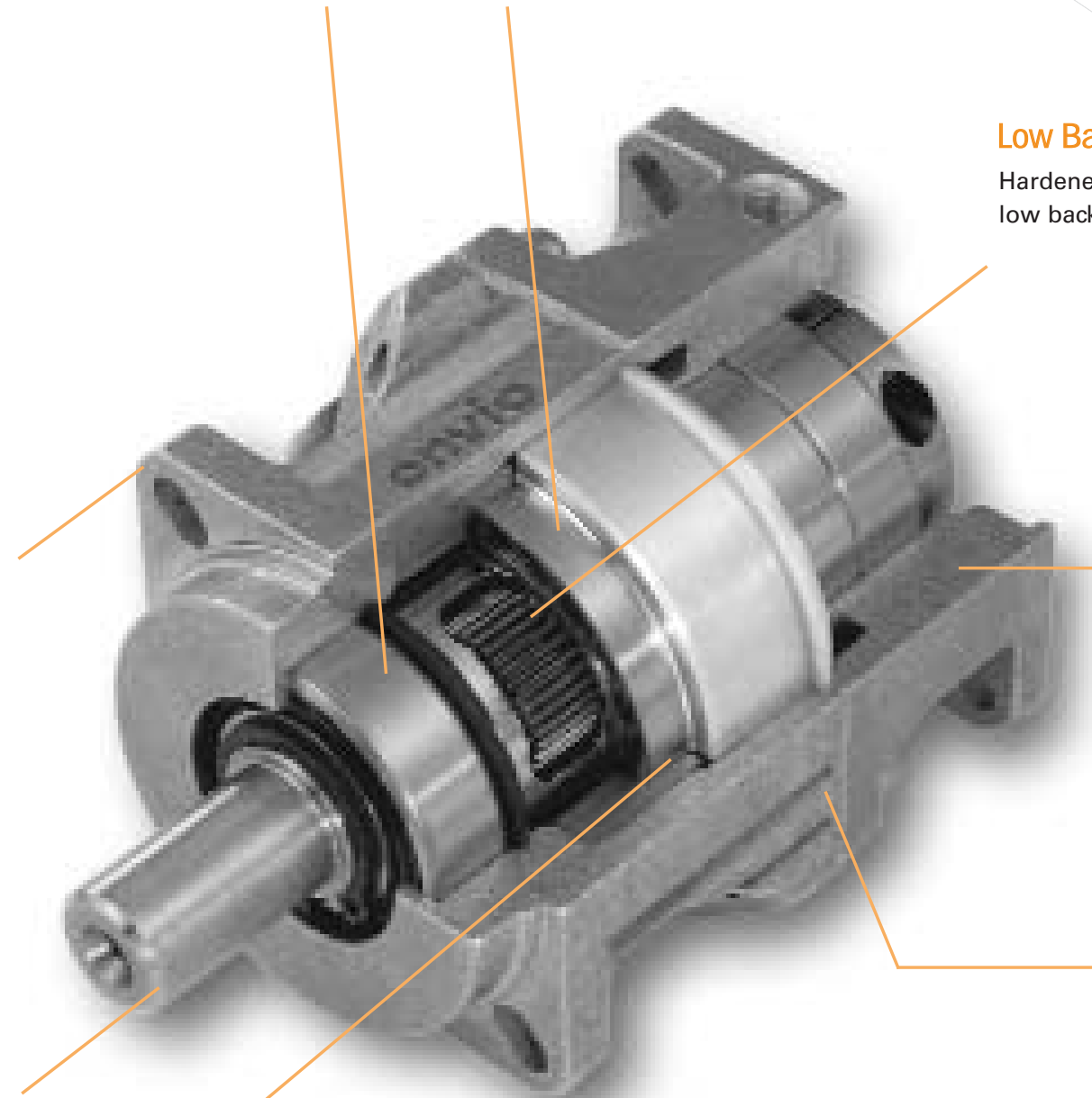

AP Speed Reducer

# AP Speed Reducers

Motor Interface A

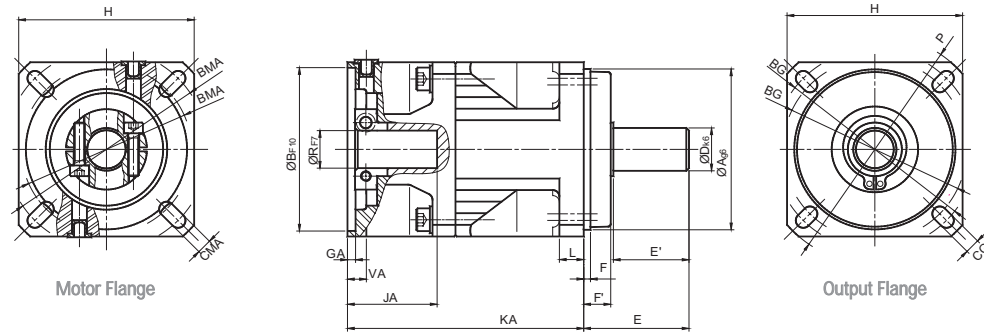

Motor Interface B

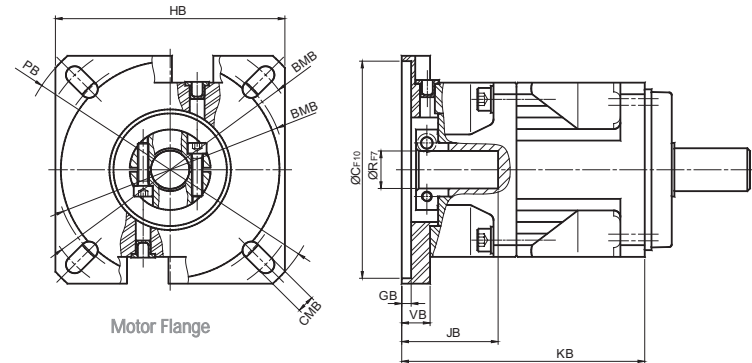

## AP Dimensions (mm)

Size		AP-010	AP-020	AP-030	AP-040	AP-050
Square Flange	H	65	85	115	142	190
Pilot Ø	A g 6	60	70	100	130	160
Output Shaft Ø	D k 6	16	22	32	40	55
Mounting Bolt Circle	BG	68 - 75	85 - 100	115 - 130	165	215
Mounting Holes	CG 4 x 90°	5.5	6.6	8.5	11	13
Flange Thickness	L	9	11	13	18	22
Outside Ø	P	86	113	152	187	246
Length: Mounting Flange to Shaft End	E	39	49	85	112	112
Usable Shaft Length	E'	28	36	58	82	82
Pilot Length	F	2.5	3	4	8	10
Shoulder Length	F'	10	12	25	27	27
Body Length with A Flange	KA	87.5	118.5	156.5	136.5	182
		-	-	-	187.5	242
Body Length with B Flange	KB	90	128.5	157.5	136.5	-
		-	-	-	187.5	-

### Motor Interface Dimensions

		A	B	A	B	A	B	A	B	A	B
Maximum Motor Pilot Ø	B	61	81	81	101	111	131	131	181	181	-
Maximum Pilot Length	G	3	3.5	3.5	4	4	4	5	5.5	6	-
Square Flange	H	65	85	85	115	115	142	142	190	190	-
Motor Bolt Circle Range	BM	63 - 75	85 - 100	85 - 100	115 - 130	115 - 130	145 - 165	145 - 165	200 - 215	200 - 215	-
Mounting Holes	CM	5.5	6.5	6.6	8.5	8.5	11	11	13	13	-
Flange Thickness	V	7	10.5	10	16	12	15	15	18	20	-
Flange Ø	P	86	114	113	149	152	188	187	246	246	-
Maximum Motor Shaft Length	J	32	35	40	50	50	53	60	60	80	-
Maximum Motor Shaft Ø	R F 7	14*		19*		24*		32*		38*	-

\* Larger diameter available on request

## AP Output Shaft Keyway Dimensions

		AP-010	AP-020	AP-030	AP-040	AP-050
Key Width	S h 9	5	6	10	12	16
Key Length	T	22	28	45	70	70
Key Position	Q	3	4	6	5	6
Key Height	U	18	24.5	35	43	59
Thread Size	M	M5	M8	M12	M16	M20
Thread Depth	N	12.5	19	28	36	42

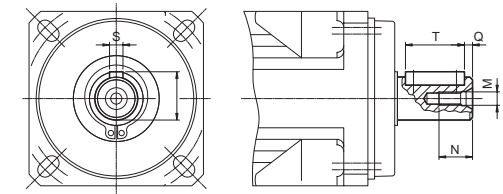

## AP Ratings

Size	U/M	AP-010		AP-020		AP-030		AP-040		AP-050			
		Rated TN	Peak TP	Rated TN	Peak TP	Rated TN	Peak TP	Rated TN	Peak TP	Rated TN	Peak TP		
Output Torque	Nm	1 stage	4	30	60	96	192	192	384	360	720	720	1440
			5	27	54	90	180	200	400	360	720	750	1500
		7	32	64	70	140	175	350	360	720	750	1500	
		9	20	40	72	144	117	234	-	-	-	-	
		10	-	-	-	-	-	-	300	600	650	1300	
	2 stage	16	31	62	96	192	192	384	360	720	720	1440	
		20	27	54	100	200	200	400	360	720	750	1500	
		28	32	64	70	140	175	350	360	720	750	1500	
		36	19	38	67	135	117	234	-	-	-	-	
		40	30	60	96	192	192	384	360	720	720	1440	
100	50	27	54	100	200	200	400	360	720	750	1500		
	70	31	62	70	140	175	350	360	720	750	1500		
	90	19	38	67	135	117	234	-	-	-	-		
	100	-	-	-	-	-	-	300	600	650	1300		
	Backlash	j t	arc min	1 stage		Reduced ≤ 3	-	Standard ≤ 6					
			2 stage		Reduced ≤ 5	-	Standard ≤ 8						
Continuous Input Speed	n1cont	RPM			3000	3000	3000	2500		2500			
Maximum Input Speed	n1max	RPM			6000	6000	6000	4000		4000			
Maximum Radial Load	Fr 2 max	N			1100	1500	4400	6900		11000			
Maximum Axial Load	Fa 2 max	N			550	750	2200	3450		5500			
Efficiency	η	%	1 stage				96						
			2 stage				94						
Input Inertia	J1	kgcm <sup>2</sup>	1 stage	4	0.1058	0.4910	2.8631	8.2290	Consult Factory				
				5	0.0937	0.4470	2.6790	7.2196					
				7	0.0840	0.4153	2.5420	6.3714					
				9	0.0799	0.4021	2.4829	-					
				10	-	-	-	5.9346					
			2 stage	16	0.0886	0.4377	2.5743	7.1797	Consult Factory				
				20	0.0880	0.4350	2.5627	7.1166					
				28	0.0873	0.4330	2.5542	7.0636					
				36	0.0870	0.4322	2.5505	-					
				40	0.0721	0.3585	2.3670	5.7486					
50	0.0720	0.3580	2.3651	5.7385									
70	0.0719	0.3577	2.3638	5.7300									
90	0.0718	0.3576	2.3632	-									
100	-	-	-	5.7256									
Weight with Interface A / B	m	kg	1 stage	1.1	1.2	2.9	3.2	6.9	7.3	Consult Factory	Consult Factory		
			2 stage	1.3	1.4	3.4	3.7	7.7	8.1	Consult Factory	Consult Factory		
Temperature Range		°C								-10°C to 90°C			
Noise (Measured @ 3000 rpm)		dB(A)								≤ 69			
Life	Lh	h								>15,000			
Lubrication					Grease					Oil			
Orientation										Any			

# HP

## HP Speed Reducers

### Greatest Flexibility

Onvio's advanced, hybrid planetary, HP, offers the precision of a planetary and the economy of a spur gear. Onvio's patented single piece spur gear construction insures proper gear mesh; available in three frame sizes with rated output torque from 40 Nm up to 180 Nm. Standard backlash is 10 arc minutes with reduced backlash of 5 arc minutes.

The HP reducer is available in twelve standard ratios from 10:1 up to 95:1. The planetary stage is constant at 5:1 while the overall ratio is achieved by changing the spur gear ratio.

To change ratios, the spur gear cartridge can be changed in the field in minutes.

Manufactured with the same two-piece modular design as the AP, Onvio's HP gearbox can be customized to meet your OEM requirements.

- Custom housing designs
- Washdown environments
- Integrated servo motor design
- Various lengths of output shaft
- Wide range of operating temperatures

*For applications that require a smooth, quiet running gearbox, with low to medium backlash, select Onvio's HP servo reducer.*

#### Universal Servo Interface

Flexible slotted bolt circle and oversized pilot allow easy motor installation and no adapters

Floating pilot and high capacity input bearings guarantee alignment between motor and gearbox

#### Modular High Tech Design

Can be universally mounted

#### Low Input Inertia

Spur gear input stage has lower inertia than true planetary gears

Ideal for high cycling start/stop applications and shorter acceleration/deceleration times

#### Quiet and Smooth

Single piece spur gear cartridge and urethane o-rings provide outstanding dampening characteristics

#### Outstanding Value

Best combination of size, accuracy, reliability and ease of use

#### Cool Operation

Unique fins dissipate heat from the motor and reduce gearbox weight

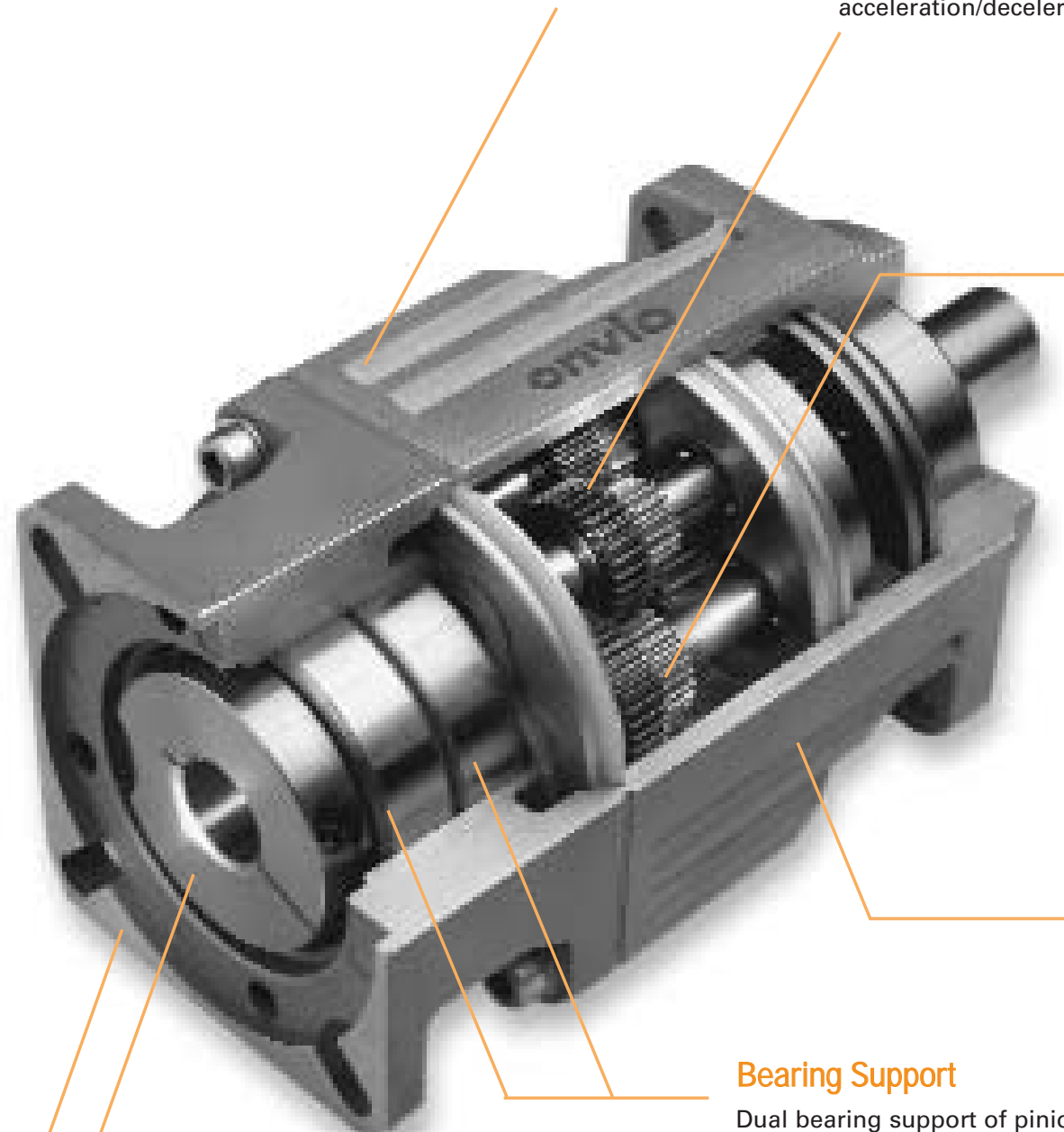

#### Bearing Support

Dual bearing support of pinion removes all load from motor bearing

## HP Speed Reducer

# HP Speed Reducers

Motor Interface A

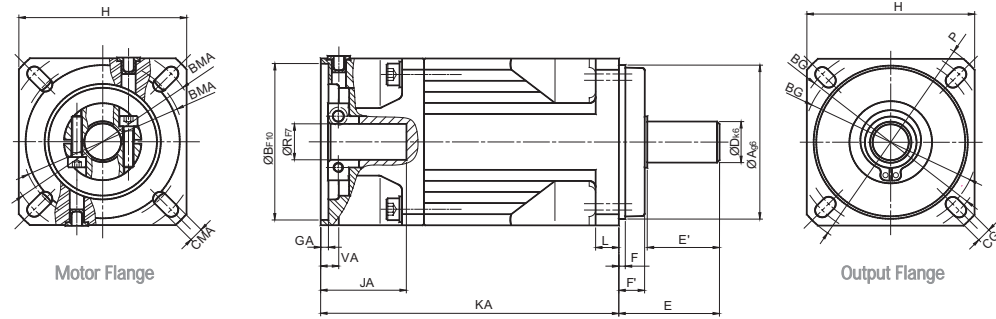

Motor Interface B

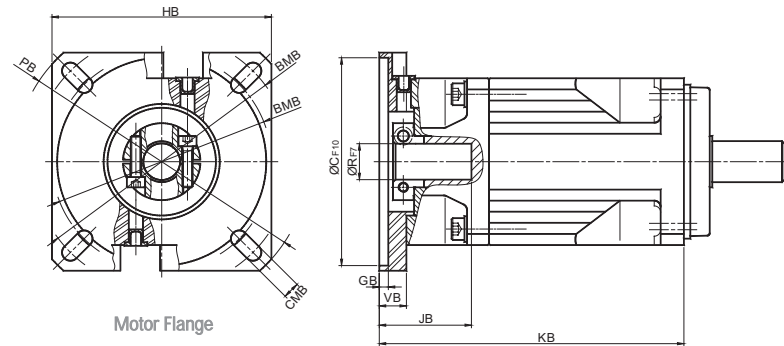

## HP Dimensions (mm)

Size		HP-010	HP-020	HP-030
Square Flange	H	65	85	115
Pilot Ø	A g 6	60	70	100
Output Shaft Ø	D k 6	16	22	32
Mounting Bolt Circle	BG	68 - 75	85 - 100	115 - 130
Mounting Holes	CG 4 x 90°	5.5	6.6	8.5
Flange Thickness	L	9	11	13
Outside Ø	P	86	113	152
Length: Mounting Flange to Shaft End	E	39	49	85
Usable Shaft Length	E'	28	36	58
Pilot Length	F	2.5	3	4
Shoulder Length	F'	10	12	25
Body Length with A Flange	KA	115.5	153.5	200
Body Length with B Flange	KB	118	163.5	201

### Motor Interface Dimensions

		A	B	A	B	A	B
Maximum Motor Pilot Ø	B	61	81	81	101	111	131
Maximum Pilot Length	G	3	3.5	3.5	4	4	4
Square Flange	H	65	85	85	115	115	142
Motor Bolt Circle Range	BM	63 - 75	85 - 100	85 - 100	115 - 130	115 - 130	145 - 165
Mounting Holes	CM	5.5	6.5	6.6	8.5	8.5	11
Flange Thickness	V	7	10.5	10	16	12	15
Flange Ø	P	86	114	113	149	152	188
Maximum Motor Shaft Length	J	32	35	40	50	50	53
Maximum Motor Shaft Ø	R F 7	14*		19*		24*	

\* Larger diameter available on request

## HP Output Shaft Keyway Dimensions

			HP-010	HP-020	HP-030
Key Width	S h 9		5	6	10
Key Length	T		22	28	45
Key Position	Q		3	4	6
Key Height	U		18	24.5	35
Thread Size	M		M5	M8	M12
Thread Depth	N		12.5	19	28

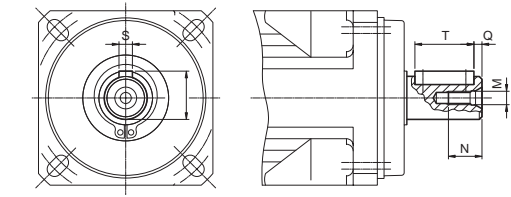

## HP Ratings

Size	U/M	Ratio	HP-010		HP-020		HP-030		
			Rated TN	Peak TP	Rated TN	Peak TP	Rated TN	Peak TP	
Output Torque	Nm	1 stage	10	10	15	25	50	60	120
			15	15	22.5	37.5	75	90	180
		2 stage	20	20	30	50	100	120	240
			25	25	37.5	62.5	125	150	300
			30	30	45	75	150	180	360
			40	40	60	90	180	180	360
			50	40	75	90	180	180	360
			60	40	78	90	180	180	360
		2 stage	80	40	80	90	180	180	360
			95	40	80	90	180	180	360

Backlash	jt	arc min	Reduced	≤ 5	Standard	≤ 10
Continuous Input Speed	n1cont	RPM	3000	3000	3000	
Maximum Input Speed	n1max	RPM	6000	6000	6000	
Maximum Radial Load	Fr 2max	N	1100	1500	4400	
Maximum Axial Load	Fa 2max	N	550	750	2200	

Efficiency	η	%	1 stage	96
			2 stage	94

Input Inertia	J1	kgcm <sup>2</sup>	1 stage	10	0.0865	0.4237	2.4404
				15	0.0795	0.4017	2.3931
			2 stage	20	0.0770	0.3937	2.3762
				25	0.0763	0.3922	2.3706
				30	0.0758	0.3904	2.3666
				40	0.0749	0.3873	2.3613
				50	0.0757	0.3908	2.3637
				60	0.0754	0.3894	2.3618
			2 stage	80	0.0746	0.3868	2.3586
				95	0.0743	0.3856	2.3573

Direction of Rotation (Input to Output)	1 stage	Opposite
	2 stage	Same

Weight with Interface A / B	m	kg	1 stage	1.4	1.5	3.15	3.5	7.65	7.95
			2 stage	1.6	1.47	3.2	3.55	7.8	8.1

Temperature Range	°C	-10°C to 90°C
-------------------	----	---------------

Noise (Measured @ 3000 rpm)	dB(A)	≤ 69
-----------------------------	-------	------

Life	Lh	h	>15,000
------	----	---	---------

Lubrication	Grease	Oil	Oil
-------------	--------	-----	-----

Orientation	Any
-------------	-----

# AL

## AL Speed Reducers

### Best Value

Onvio's value planetary, AL, provides designers with an economical, precision planetary gearbox that is perfect for today's stepper and emerging low cost servo motors. The design incorporates single or two stages of planetary gearing to create four frame sizes with rated torque from 6 Nm up to 100 Nm. Gearboxes are produced with less than 12 arc minutes of backlash in a single stage and less than 15 arc minutes in a two stage gearbox.

The AL reducer is available in eight standard ratios from 3:1 to 100:1.

The cylindrical housing is supplied with either face mounted holes or a square NEMA flange making it a versatile gearbox for global installation.

*Select Onvio's AL gearbox when your requirements call for an economical precision gearbox.*

#### Universal Servo Interface

Flexible slotted bolt circle and oversized pilot allow easy motor installation and no adapters

#### Interchangeability

Mechanically interchangeable with many of today's metric gearboxes or supplied with a NEMA flange

#### One Piece Construction

Steel body with hardened, integral crown gear provides strength and precision in a small diameter

#### Maintenance Free Operation

Grease filled for life; never needs service

#### Outstanding Value

Precise, simple design offers mid-range backlash at a low cost

#### Output Bearing

Forward output bearing construction allows for higher bearing loads and serves as a pilot helping to provide a more economical package

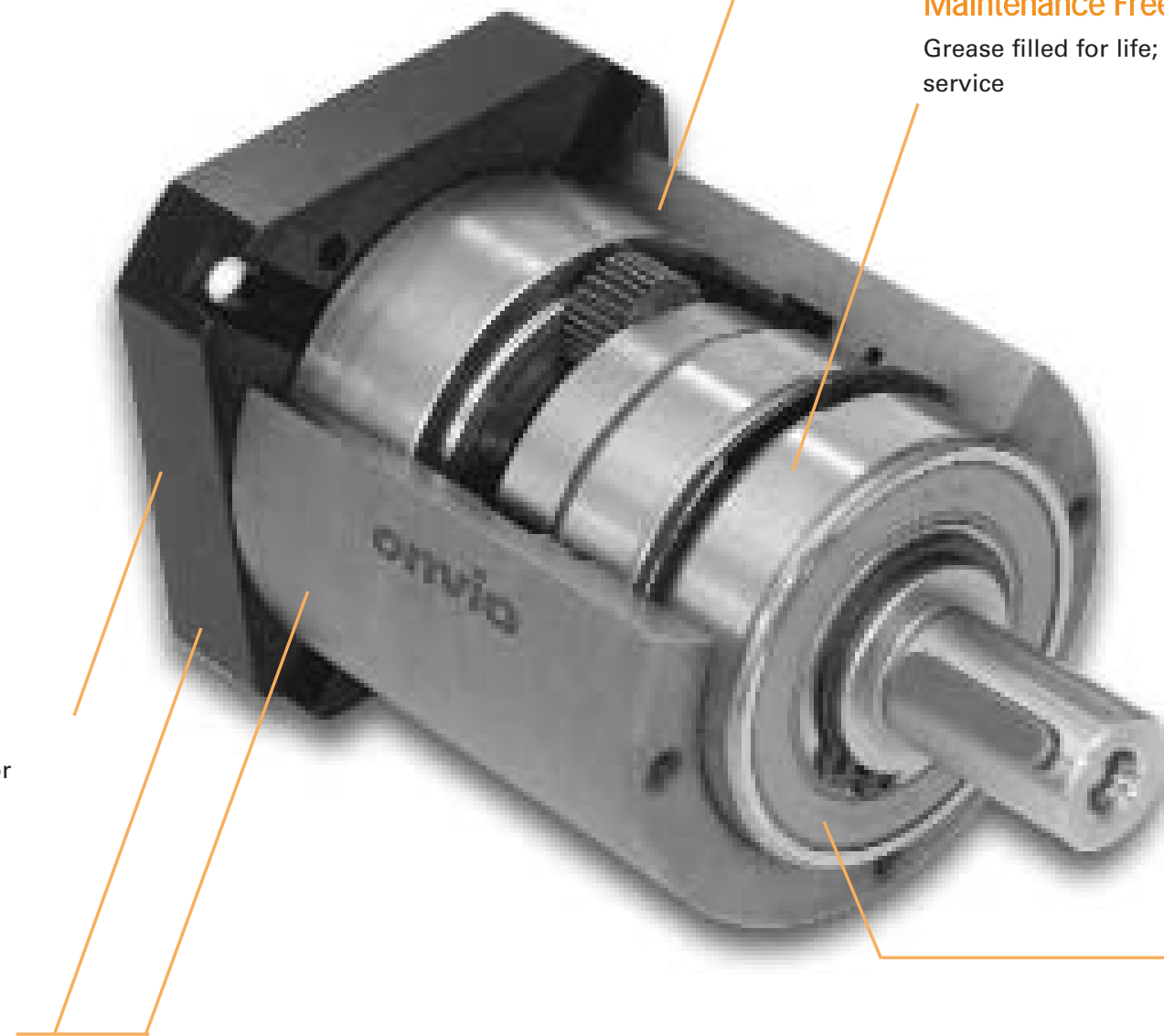

## AL Speed Reducer

# AL Speed Reducers

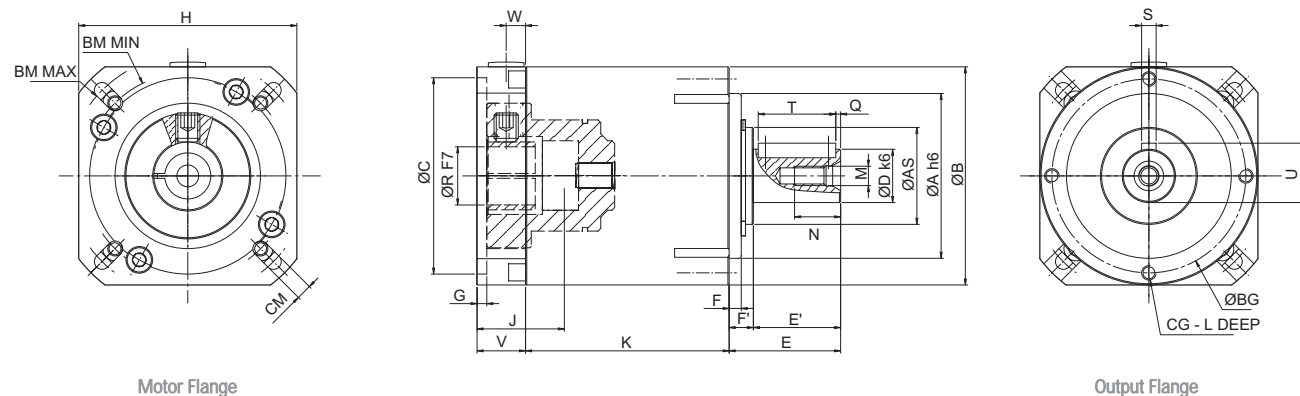
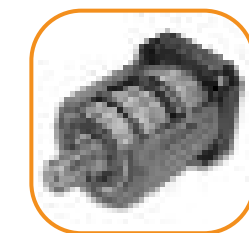

## AL Dimensions (mm)

Size		AL-005	AL-010	AL-020	AL-030	
Housing Ø	B	50	70	90	120	
Pilot Ø	A	h6	52	68	90	
Output Shaft Ø	D	k6	12	22	32	
Mounting Bolt Circle	BG	44	62	80	108	
Mounting Holes	CG	4x90°	M4	M5	M8	
Shoulder Ø	AS	17	25	40	50	
Shaft Length from Mount Face	E	24.5	36	46	70	
Output Shaft Length	E'	18	28	36	58	
Pilot Length	F	4	5	5	6	
Thickness	F'	6.5	8	10	12	
Thread Depth	L	8	10	12	16	
Keyway Length	T	14	22	32	50	
Keyway Position	Q	2	3	2	4	
Height with Key	U	13.5	18	24.5	35	
Key Width	S	h9	4	5	10	
Thread Size	M	M4	M5	M8	M12	
Thread Depth	N	8	10	13	28	
Reducer Body Length	K	1 stage	48	69	84	103.5
		2 stage	64	90	110	136

### Motor Interface Dimensions

		A	B	A	D	B	E	A	D	B	E	A	D	B	E
Maximum Motor Pilot Ø	C	52	62	62	81	81	101	112	131						
Maximum Pilot Length	G	4		4	5	6	6	4	4	4	4	6	6	6	6
Square Flange	H	55	70	70	90	90	120	120	150						
Bolt Circle for Motor	BM	55-63	63-75	63-75	85-100	85-100	115-130	115-130	145-165						
Mounting Holes	CM	5.3	5.3	5.3	5.3	6.6	6.6	6.4	6.4	8.5	8.5	8.5	8.5	11	11
Flange Thickness	V	20	25	16.5	19.5	19.5	30	20	25	25	35	26	34	36	44
Maximum Motor Shaft Length	J	25	30	16.5	19.5	19.5	30	24	29	29	39	26	34	36	44
Minimum Motor Shaft Length	J	18	23	27	30	30	40	35	40	40	50	42	50	52	60
Maximum Motor Shaft Ø	R	14		16				24				32			
Position of Access Hole	W	6		7				8				10			

## AL Ratings

Size	U/M		AL-005		AL-010		AL-020		AL-030		
			Ratio	Rated TN	Peak TP	Rated TN	Peak TP	Rated TN	Peak TP	Rated TN	Peak TP
Output Torque	Nm	1 stage	3	NA	NA	22	44	40	80	100	200
			5	6	12	22	44	40	80	100	200
			10	5.5	11	20	40	37	74	90	180
		2 stage	15	NA	NA	22	44	40	80	100	200
			25	6	12	22	44	40	80	100	200
			30	6	12	22	44	40	80	100	200
			50	6	12	22	44	40	80	100	200
100	5.5	11	20	40	37	74	90	180			
Backlash	arc min	1 stage	≤ 12		≤ 12		≤ 12		≤ 12		
		2 stage	≤ 15		≤ 15		≤ 15		≤ 15		
Torsional Stiffness	Nm/arc min	1 stage	3	NA		3.3		9		24	
			5	0.9		3.3		9		24	
			10	0.75		2.8		7.5		20.5	
		2 stage	15	NA		3.3		9		24	
			25	0.9		3.3		9		24	
		30	0.9		3.3		9		24		
		50	0.9		3.3		9		24		
		100	0.75		2.8		7.5		20.5		
Continuous Input Speed	RPM		4000		3700		3400		2600		
Maximum Input Speed	RPM		8000		6000		6000		4800		
Maximum Radial Load	N		650		1450		2400		4600		
Maximum Axial Load	N		700		1550		1900		4000		
Efficiency	%	1 stage					> 97				
		2 stage					> 95				
Input Inertia	kgcm <sup>2</sup>	1 stage	0.06		0.29		1.73		5.50		
		2 stage	0.05		0.26		1.48		4.60		
Weight	kg	1 stage	0.75		1.7		4.0		8.8		
		2 stage	0.92		2.1		4.9		10.9		
Noise Level	dB (A)	Measured @ 3000 rpm	≤ 69		≤ 70		≤ 72		≤ 74		
Life	h						20,000				
Lubrication							Grease				
Orientation							Any				



# NEMA Speed Reducers

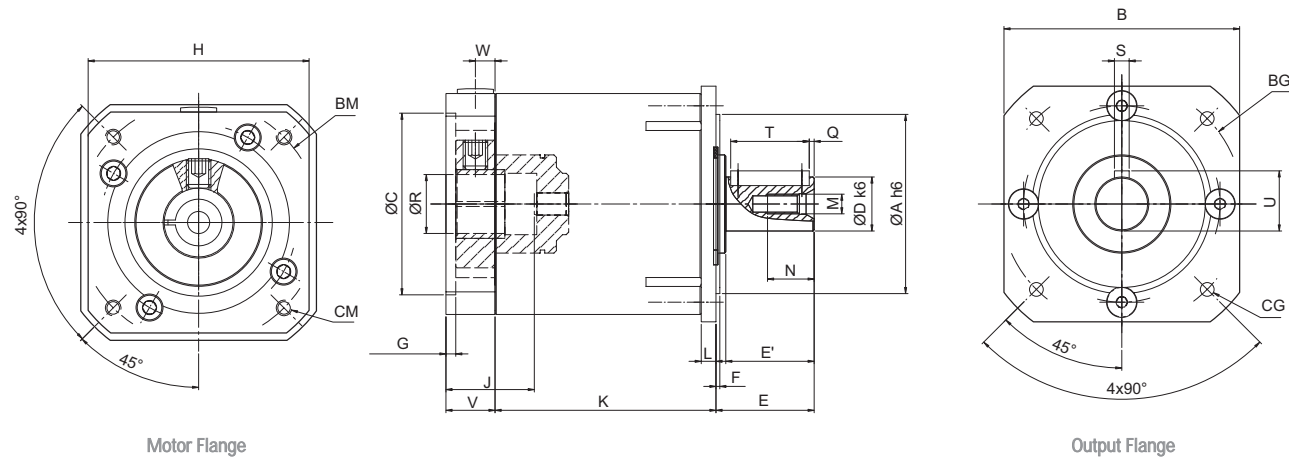

## NEMA Dimensions (mm)

Size			NEMA-017	NEMA-023	NEMA-034	NEMA-042
Square Flange	B		2.13	2.99	3.78	5.00
Pilot Ø	A	h6	0.867	1.500	2.875	2.185
Output Shaft Ø	D	k6	0.472	0.630	0.866	1.260
Mounting Bolt Circle	BG		1.725	2.625	3.875	4.950
Mounting Holes	CG		0.126	0.204	0.220	0.283
Shaft Length from Mount Face	E		0.689	1.122	1.575	2.256
Output Shaft Length	E'		0.591	1.060	1.417	2.194
Pilot Length	F		0.098	0.062	0.158	0.062
Flange thickness	L		0.18	0.20	0.24	0.50
Keyway Length	T		0.551	0.866	1.260	1.969
Keyway Position	Q		0.079	0.118	0.079	0.157
Height with Key	U		0.531	0.708	0.965	1.378
Key Width	S	h9	0.157	0.197	0.236	0.394
Thread Size	M		M4	M5	M8	M12
Thread Depth	N		0.315	0.394	0.512	0.866
Reducer Body Length	K	1 stage	2.95	3.69	3.54	4.58
		2 stage	3.58	4.54	4.57	5.85

## Motor Interface Dimensions

Motor Pilot Ø	C		1.259	1.535	2.875	2.185
Pilot Length	G		0.098	0.062	0.158	0.185
Square Flange	H		2.165	2.756	3.543	4.724
Bolt Circle for Motor	BM		1.725	2.625	3.875	4.950
Mounting Holes	CM		(4) #4-40 UNC	(4) #10-32 UNC	(4) 1/4-20 UNC	(4) 1/4-20 UNC
Flange Thickness	V		0.790	0.649	0.788	1.024
Maximum Motor Shaft Length	J		0.985	0.945	1.377	1.653
Minimum Motor Shaft Length	J		0.708	0.708	0.945	1.023
Maximum Motor Shaft Ø	R		0.551	0.629	0.945	1.259
Position of Access Hole	W		0.236	0.275	0.315	0.394

## NEMA Ratings

Size	U/M		NEMA-017		NEMA-023		NEMA-034		NEMA-042		
			Ratio	Rated TN	Peak TP	Rated TN	Peak TP	Rated TN	Peak TP	Rated TN	Peak TP
Output Torque	Lb-In	1 stage	3	NA	NA	195	390	354	708	885	1770
			5	53	106	195	390	354	708	885	1770
			10	49	97	177	354	327	654	797	1594
		2 stage	15	NA	NA	195	390	354	708	885	1770
			25	53	106	195	390	354	708	885	1770
			30	53	106	195	390	354	708	885	1770
			50	53	106	195	390	354	708	885	1770
100	49	97	177	354	327	654	797	1594			
Backlash	arc min	1 stage	≤ 12		≤ 12		≤ 12		≤ 12		
		2 stage	≤ 15		≤ 15		≤ 15		≤ 15		
Torsional Stiffness	Lb In/arc min	1 stage	3	NA		29.2		79.6		212	
			5	7.16		29.2		79.6		212	
			10	6.64		24.8		66.4		177	
		2 stage	15	NA		29.2		79.6		212	
			25	7.16		29.2		79.6		212	
			30	7.16		29.2		79.6		212	
50	7.16		29.2		79.6		212				
100	6.64		24.8		66.4		177				
Continuous Input Speed	RPM		4000		3700		3400		2600		
Maximum Input Speed	RPM		8000		6000		6000		4800		
Maximum Radial Load	Lb		150		326		540		613		
Maximum Axial Load	Lb		157		350		427		900		
Efficiency	%	1 stage					> 97				
		2 stage					> 95				
Input Inertia	kgcm <sup>2</sup>	1 stage	5.31 x 10 <sup>-5</sup>		2.57 x 10 <sup>-4</sup>		1.53 x 10 <sup>-3</sup>		4.87 x 10 <sup>-3</sup>		
		2 stage	4.42 x 10 <sup>-5</sup>		2.30 x 10 <sup>-4</sup>		1.31 x 10 <sup>-3</sup>		4.07 x 10 <sup>-3</sup>		
Weight	kg	1 stage	6.64 x 10 <sup>-4</sup>		1.50 x 10 <sup>-3</sup>		3.54 x 10 <sup>-3</sup>		7.79 x 10 <sup>-3</sup>		
		2 stage	8.14 x 10 <sup>-4</sup>		1.86 x 10 <sup>-3</sup>		4.34 x 10 <sup>-3</sup>		9.65 x 10 <sup>-3</sup>		
Noise Level	dB (A)	Measured @ 3000 rpm	≤ 69		≤ 70		≤ 72		≤ 74		
Life	h						20,000				
Lubrication							Grease				
Orientation							Any				

# Conversions

Torque	1Nm = 8.85 Lb In
Stiffness	1Nm/arc min = 8.85 Lb In/arc min
Inertia	1Kgcm <sup>2</sup> = 8.85 x 10 <sup>4</sup> Lb In sec <sup>2</sup>
Weight	1Kg = 2.2 Lbs
Force (Bearing Loads)	1 Newton = .2248 Lbs
Dimensional	1mm = .03937 inches

# Easy to Order



Onvio's unique interface design offers an oversized pilot and slotted holes. The motor bearing is free of side load, resulting in longer life and better performance.

Simplified ordering and shortened delivery time because Onvio offers standard flanges for almost any motor. Match the motor mounting dimensions with the proper flange and insert the corresponding letter into the catalog number when ordering.

**HP - 030 - 015 - 05 - A240 - N - N - XXX**

**Model:** \_\_\_\_\_

AP = Authentic Planetary  
HP = Hybrid Planetary  
AL = Economy Planetary  
NE = NEMA Planetary

**Size:** \_\_\_\_\_

010 - 020 - 030 - 040 - 050  
017 - 023 - 034 - 042

**Ratio:** See data for availability  
Example Ratio 05 = 5:1, 010 = 10:1

**Backlash:** See data for availability  
05 = < 5 arc min , 10 = < 10' arc min

Reserved for Specials  
Consult Factory

**Output Shaft:**  
N = Standard  
V = Spline  
P = With Keyway  
S = Special

**Housing:**  
N = Standard  
F = Footmount  
S = Special

**Motor Interface:**  
A, B, D, E - See catalog data  
G - NEMA  
X - Special  
Motor Shaft Ø (expressed in mm)  
Example Ø9mm = 090  
Ø.500inch = 127

**Determine Order Number**

# Additional Reducer Products



Dojen™

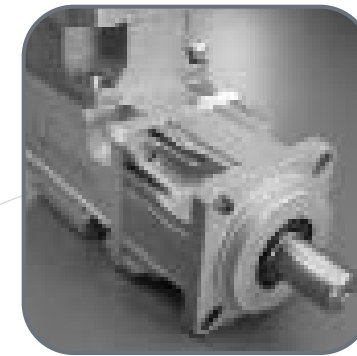

Right Angle



Power Pulley



Timing Pulleys



Power Roller

## Dojen™

When ultimate precision or compact size is crucial to your machine design, Onvio manufactures the Dojen™ Zero Backlash Cycloidal Speed Reducer. The Dojen uses a cam follower design. Each cam follower is pre-loaded individually against the cam, insuring constant contact between all force transmitting components. Onvio offers 9 frame sizes with torques ranging from 15 Nm up to 3842 Nm with 49 available ratios from 9:1 up to 256:1.

## Right Angle

In keeping with Onvio's modular concept, the right angle module is a self contained, helical bevel stage that can bolt directly on to all of Onvio's AP series products. This module provides ratios of 1:1, 3:1 and 5:1 as a standalone gearbox or attaches to our AP gearbox for ratios of 100:1.

## Power Pulley

Onvio has combined the transmission strength of a speed reducer and the compact size of a pulley in our revolutionary gearbox in a pulley. Some of the advantages include 30% lower system cost due to fewer components, as well as higher reliability and better dynamic response.

## Power Roller

Onvio's new power roller incorporates a servo motor or an induction motor to match any precision requirement. Our modular designs can be supplied in widths from .5 meters up to more than 1 meter. Onvio's power roller provides torques of more than 30 Nm with linear speeds of up to 3.1 meters/second.

## Timing Pulleys

Onvio manufactures a complete line of timing pulleys for use in linear applications. Pulleys are made of aluminum, steel or stainless steel and can be supplied as complete pulley assemblies, finished pulleys or bar stock.

For questions on any of these products, contact Onvio at 1-866-685-0404 or by email at [contact@onviollc.com](mailto:contact@onviollc.com).





[www.onviolc.com](http://www.onviolc.com)

**USA**  
**CORPORATE HEADQUARTERS**

Onvio LLC  
20 Northwestern Drive  
Salem, NH 03079  
Tel. +1 (603) 685-0404  
Tel. +1 (866) 685-0404  
Fax +1 (603) 685-0405  
email: [contact@onviolc.com](mailto:contact@onviolc.com)

**GERMANY**

Onvio GmbH  
Werner von Siemens Strasse 2  
64319 Pfungstadt  
Tel. +49 (0) 6157-9727-0  
Fax +49 (0) 6157 9727-273  
email: [info@onviolc.de](mailto:info@onviolc.de)

**SPAIN**

Onvio S.L.  
Av. President John F. Kennedy, 20-A  
E-08320 el Masnou  
Barcelona  
Tel. +34 (93) 540 72 54  
Fax +34 (93) 540 72 97  
email: [onviolc@onviolc.com](mailto:onviolc@onviolc.com)