

# Plane mirrors and mirror mounts

The Renishaw RLE fibre optic laser encoder uses interferometry to provide high resolution, high linearity position feedback.

An RLE system comprises an RLU laser unit, one or two RLD10 detector heads and an additional, target optic - either a plane mirror or a retroreflector, to complete the interferometer configuration.

Whilst Renishaw does not manufacture mirrors, various length mirrors and corresponding mirror mounts can be supplied. This data sheet provides specification details for these mirrors and mirror mounts.

Mirror selection and integration should be carried out carefully to avoid degrading the metrological advantages of the interferometer system. In the case of an X-Y stage system, mirrors can contribute to system errors through:

- Surface non-uniformity (flatness), which can be minimised by using an optically flat mirror and proper mounting techniques
- Thermal expansion, which can be reduced by using the correct substrate materials and mounting techniques
- Misalignment, which can be avoided through careful installation

## General outline and dimensions

Dimensions in mm (inches)

### Overall dimensions - plane mirrors:

Length:  $L + 20$  ( $L + 0.79$ )

Cross section: 25 (0.98)

Where  $L$  = optical aperture

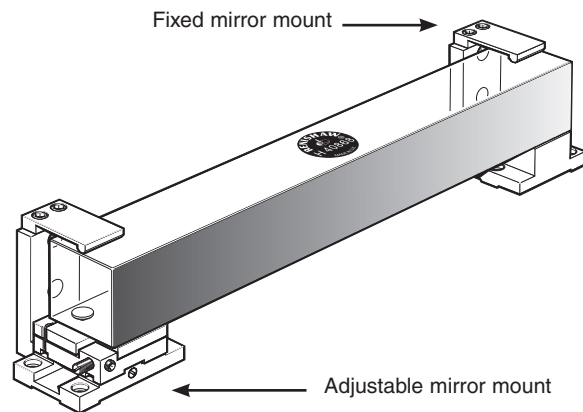

## Renishaw plane mirrors

Mirrors can be ordered using the following part number:

RPM10-YX-XX

Y = modified for Renishaw mounts  
N = not modified for Renishaw mounts

Optical aperture (in cm): 06 - 30, increments of 1 cm only

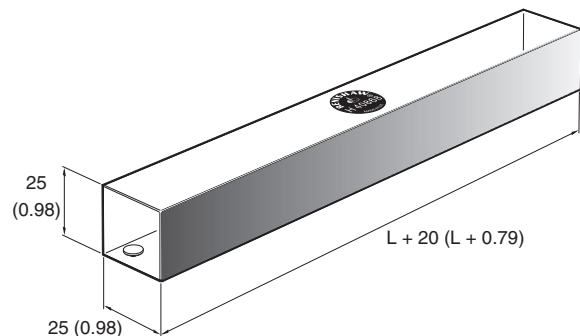

## Plane mirror specification

### Reflected beam characteristics

Intensity of the reflected beam >97% of incident beam

Cross polarisation <0.5%

### Mirror aperture area

Local flatness < $\lambda/10$  over an area 12 mm x 7 mm ( $\lambda = 633$  nm)

Ripple <0.5  $\mu$ m per 500 mm

Total flatness < $\lambda/10$  per 100 mm ( $\lambda = 633$  nm); <5  $\mu$ m per 500 mm

### Substrate

Material Zerodur® or equivalent

## Plane mirror specification (continued)

### Cosmetics

Scratch/dig	US-MIL-0-13830A 60/40 To be met by a sum of no less than 3 features within 12 mm x 3 mm area No two scratches/digs permissible within 12 mm x 3 mm area
-------------	---

### Operating environment

Temperature	10 °C to 40 °C
Air pressure	Mirrors are vacuum compatible (down to 10 <sup>-8</sup> mbar). Mirror mounts are not vacuum compatible
Relative humidity	0% to 95% non-condensing

## Renishaw mirror mount kit

Renishaw supplies three point kinematic mounts for mirrors up to 350 mm in length with a 25 mm x 25 mm cross section that allow fine pitch and yaw adjustment. The mounts are constructed to minimise errors due to differential expansion and have positional locks that provide clamping to overcome acceleration, deceleration and bump forces.

Mirror mounts can be ordered directly from Renishaw using the following part number:

RAM10-SX-XX

Renishaw supplied mirror mounts are not vacuum compatible.

Adjustment sensitivity:

- Yaw: 0.5 arc second/degree of rotation (350 mm mirror)
- Pitch: <1 arc second/degree of rotation

Necessary mirror geometry:

- 80 mm to 350 mm total length with 25 mm square cross section

Yaw adjustment:

- ±2.5° on mirrors of 80 mm length
- ±0.5° on mirrors of 350 mm length

Pitch adjustment:

- ±1°

### Overall dimensions - mirror mounts:

Height: 44 (1.73)  
Footprint: 39 x 36 (1.53 x 1.42) (adjustable mount)  
32 x 36 (1.26 x 1.42) (fixed mount)

Adjustable mirror mount

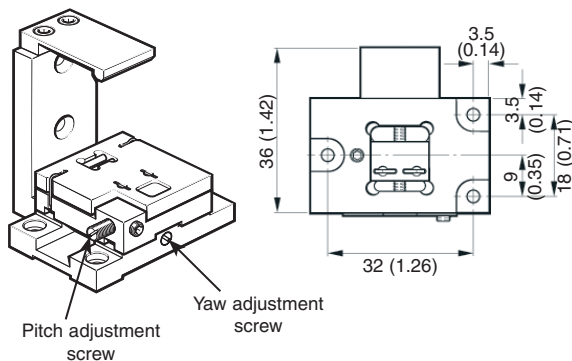

Fixed mirror mount

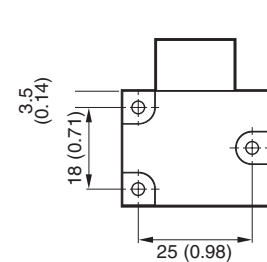

# Mirror mount installation instructions

Mirror selection and installation should be carried out carefully to avoid degrading the metrological advantages of the interferometer system.

This section details a typical alignment procedure which can be used with Renishaw mirrors and mounts to ensure errors are minimised.

The following instructions demonstrate one method for aligning two plane mirrors to an X-Y stage\* using Renishaw mirror mounts. It is assumed that:

- The person performing the procedure is familiar with the test equipment
- All mechanical adjustments of the motion stages have been completed
- The RLD10 detector heads are fully mounted
- The axes are fully operational

\* If a vertical axis of motion is located under the mirrors, a different method of pitch alignment may be necessary.

## Equipment:

- 2 x stick mirrors of required length fitted with mount locations (3 ball pads)
- 2 x Renishaw mounting kits (RAM10-SX-XX) which include:
  - 1 x adjustable mirror mount, 1 x fixed mirror mount,
  - 2 x mirror clamps, 10 x M2.5 by 8 hex head screws, 1 x Allen key (2.0 mm A/F), 1 x mount adjustment tool
- Alignment target (supplied with RLD10 90° and RLD10 0° detector heads)

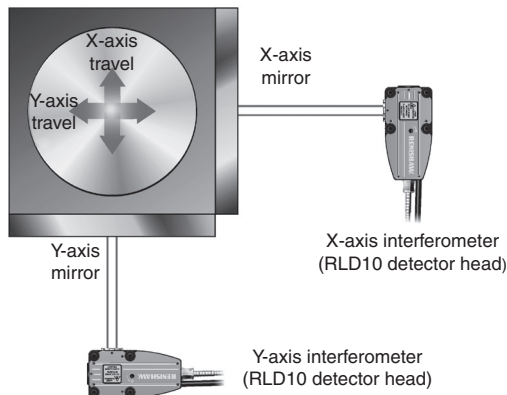

Figure 1: system terminology

### 1. Install Y-axis mirror into its mount

- The motion stage must provide fixing holes to accept the mirror mounts. These should be machined according to Figure 2 below
- Attach the adjustable mirror mount (see Figure 6 overleaf) to the stage using 3 of the M2.5 screws provided. The screws should be torqued to 0.7 Nm
- Repeat for the fixed mirror mount

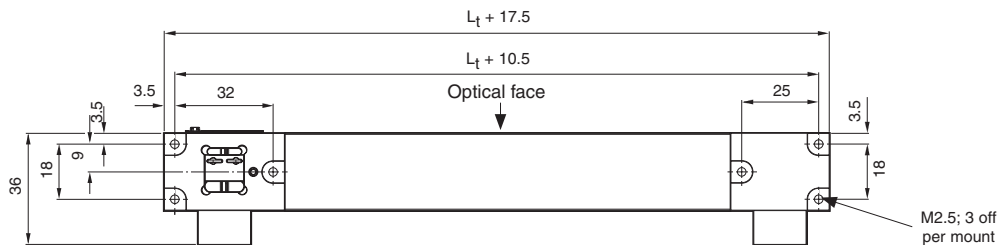

Figure 2: fixing holes for mirror of total length  $L_t$  ( $L_t \leq 350$ ); all dimensions in mm  
View from underside of mirror mounts. Note:  $L_t$  = optical aperture + 20 mm

- Locate the stick mirror on the two mounts so that the ball pads on the bottom of the mirror sit in the location features on the mounts (as in Figures 3 and 4). **Note:** two ball pads are located at the adjustable mount end and one at the fixed mount end

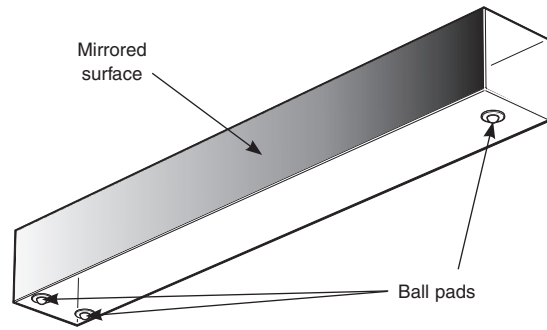

Figure 3: mirror with ball pads

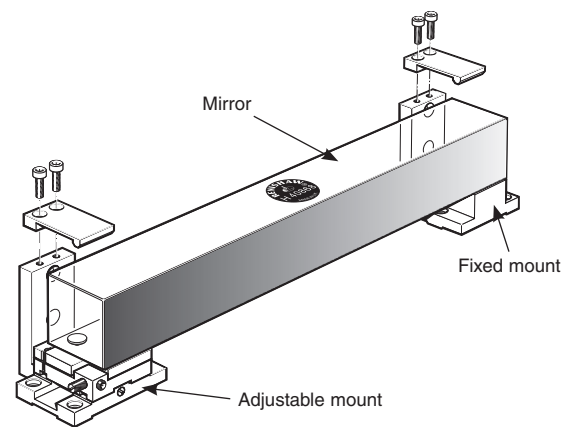

Figure 4: mirror located in mounts

### 2. Remove Y-axis interferometer (RLD10 detector head) cosine error

- Move the Y-axis (with the X-axis movement locked) to achieve the shortest separation between the Y-axis RLD10 and mirror
- Attach a Renishaw target sticker to the mirror surface so that the laser beam is on the target
- Move the axis to achieve the longest separation between the Y-axis RLD10 and mirror
- Adjust the pitch and yaw of the beam from the RLD10 so that the laser spot does not exhibit any translation from the target. **Note:** this can be an iterative process and may require multiple near and far field adjustments to achieve optimum alignment

### 3. Align the Y-axis mirror perpendicular to the Y-axis travel

- Remove the target sticker from the front of the mirror
- Move the mirror to the furthest separation and insert a metal Renishaw alignment target under the RLD10 (Figure 5 overleaf)

- Visually align the mirror yaw using the yaw adjustment screw (see Figure 6) so that the return beam is in line with the centre of the alignment target aperture (mirror is perpendicular to the X-Y plane)
- Visually align the mirror pitch using the adjustment screw (see Figure 6) so that the return beam goes through the centre of the alignment target aperture (mirror surface is now perpendicular to the X-Y plane)
- Remove the alignment target
- Finely adjust the pitch and yaw of the Y-axis mirror to maximise signal strength

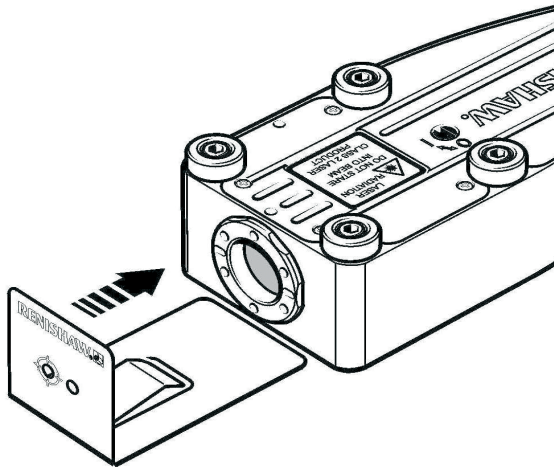

Figure 5: Renishaw alignment target

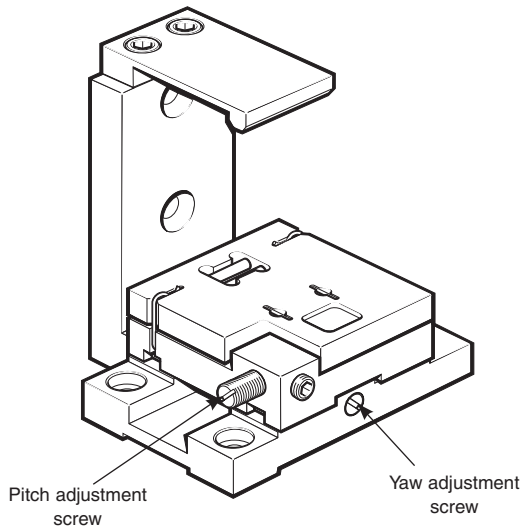

Figure 6: adjustable mirror mount

#### 4. Engage the locking mechanism on the Y-axis mirror

- Place the clamps provided on top of the mounts and half tighten with the screws provided. Torque screws on both sides to  $0.2 \text{ Nm} \pm 0.05 \text{ Nm}$
- Check the clamping process has not altered the mirror alignment - some re-adjustment of mirrors may be required

#### 5. Align the X-axis mirror and interferometer perpendicular to the X-axis by repeating steps 1, 2, 3 and 4, substituting X for Y

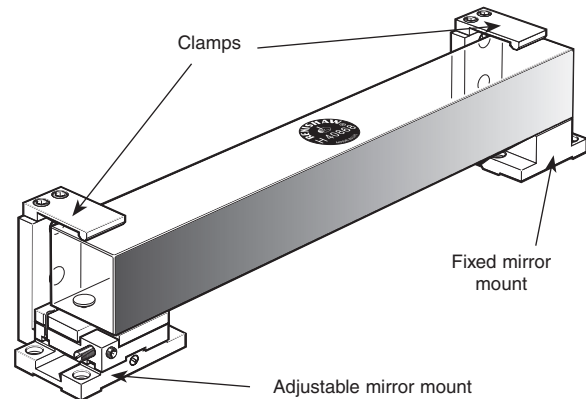

Figure 7: mirror clamped in mount

