

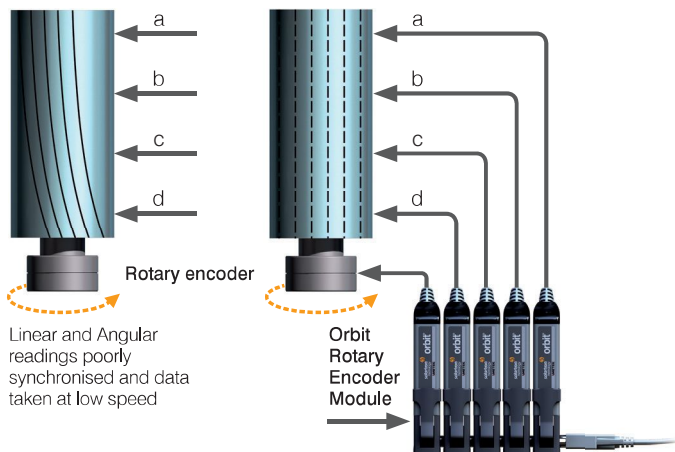

Application examples



Synchronising data

Linear and Angular readings accurately synchronised using an Orbit Rotary Encoder Module and data from linear measuring sensors taken at high speed with the Orbit Network set in Dynamic Mode.

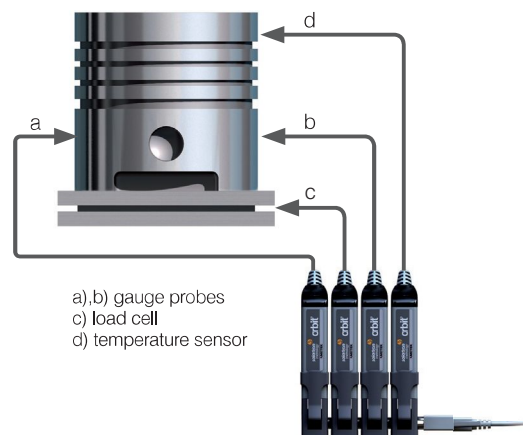

Orbit multiple sensor technology

Gauging components, such as automotive pistons and con' rods, with temperature compensation and weight measurement within the same measuring station. Orbit can also accept strain and pressure sensors where required. See pages 4 and 15.

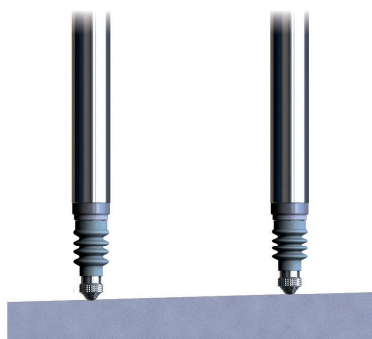

Measuring angles

The precision measurement of angles requires high resolution + excellent linearity and repeatability.

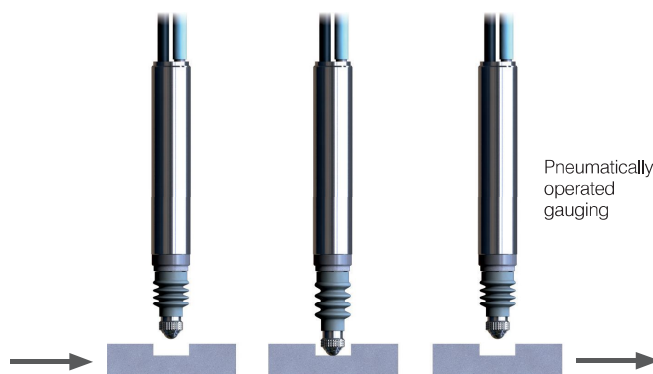

Automatic gauging systems

Automatic on line or post process is made possible with pneumatic probes and mechanical interfaces. See pages 10 and 12.

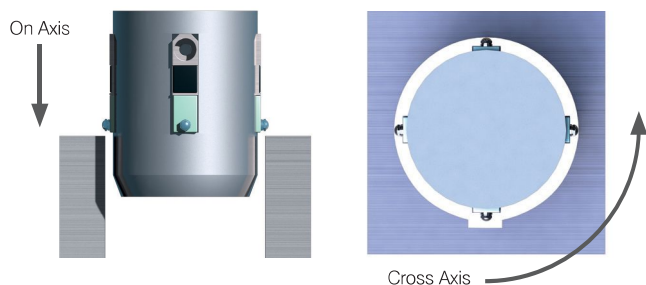

Inside diameter gauging

Dynamic Bore Gauging using Mini Probes with Orbit set in Dynamic Mode and resolution set to $0.1\mu\text{m}$. See page 12.

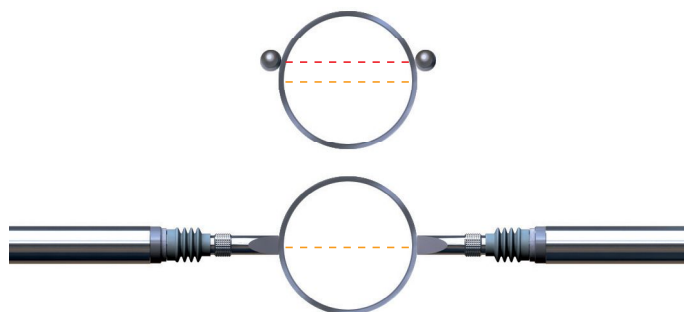

Outside diameter gauging

2 probes configured $A+B/2$ is a common method used to measure diameters. If the centre line of the ball in a ball tip is not perfectly aligned to the centre line of the component, errors can occur. The type of tip chosen for a gauging application can have a significant effect on accuracy. A tip with a knife edge or pin is often a better solution in this type of application. For a selection of tips, see page 34.





Application examples

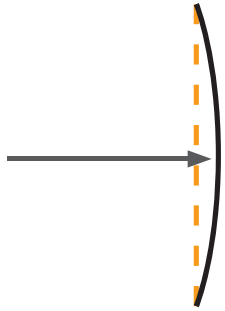

Low tip forces

Tip force is critical when gauging fragile or flexible components.

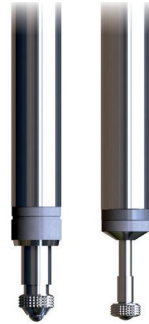

For low and very low tip force probes and special tips, see pages 8 and 10.

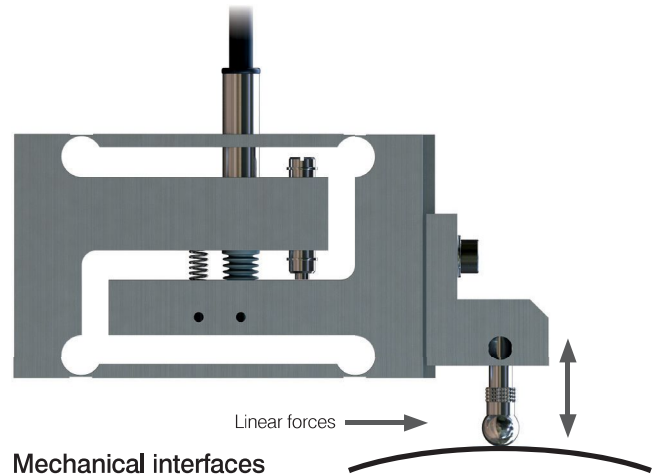

Mechanical interfaces

Flexures have the best overall performance for contact measurement of moving material. Linear forces through the flexure and no sliding components within the flexure help to ensure excellent performance and a very long life. See page 12.

Force, temperature and pressure measurement

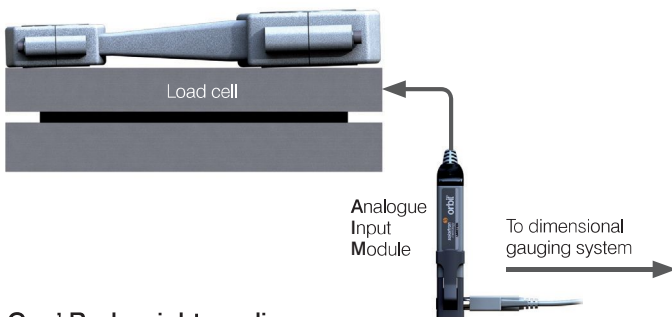

Con' Rod weight grading

By using the Orbit system to balance sets of automotive connecting rods, the customer is able to use the same software as the dimensional gauging system. A significant cost reduction can be achieved by reducing the number of sensor signal processing systems and the associated software.

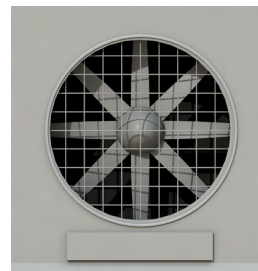

Temperature and pressure

Research into the temperature and air pressure in automotive heating and air conditioning systems is made easy with Orbit Analogue Input Modules and the Excel® support pack.

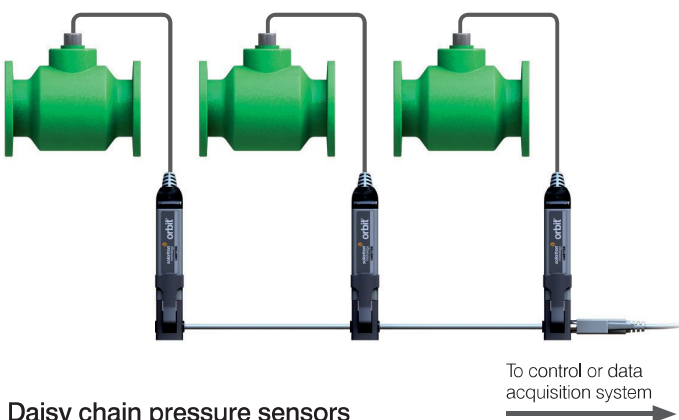

Daisy chain pressure sensors

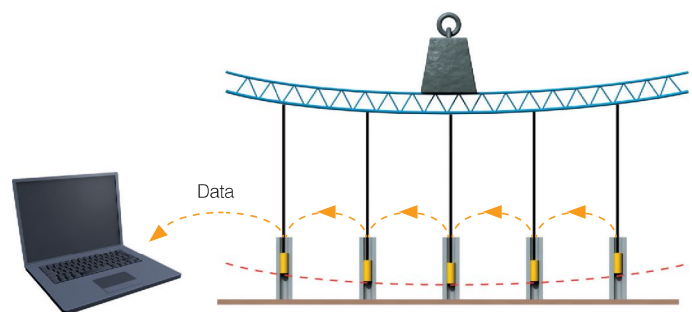

Measuring the change of the shape of a structure

Measuring the change of the shape of a structure and its recovery after being stressed is a common problem. The Orbit multi drop data acquisition system can take readings from a mix of Displacement, Strain, Pressure and Temperature sensors.

