



NEW

Finite Stroke LM Guide

Advantages of using the ball cage
Smooth motion with little rolling fluctuation
Compact body with a 4-groove structure

EPF

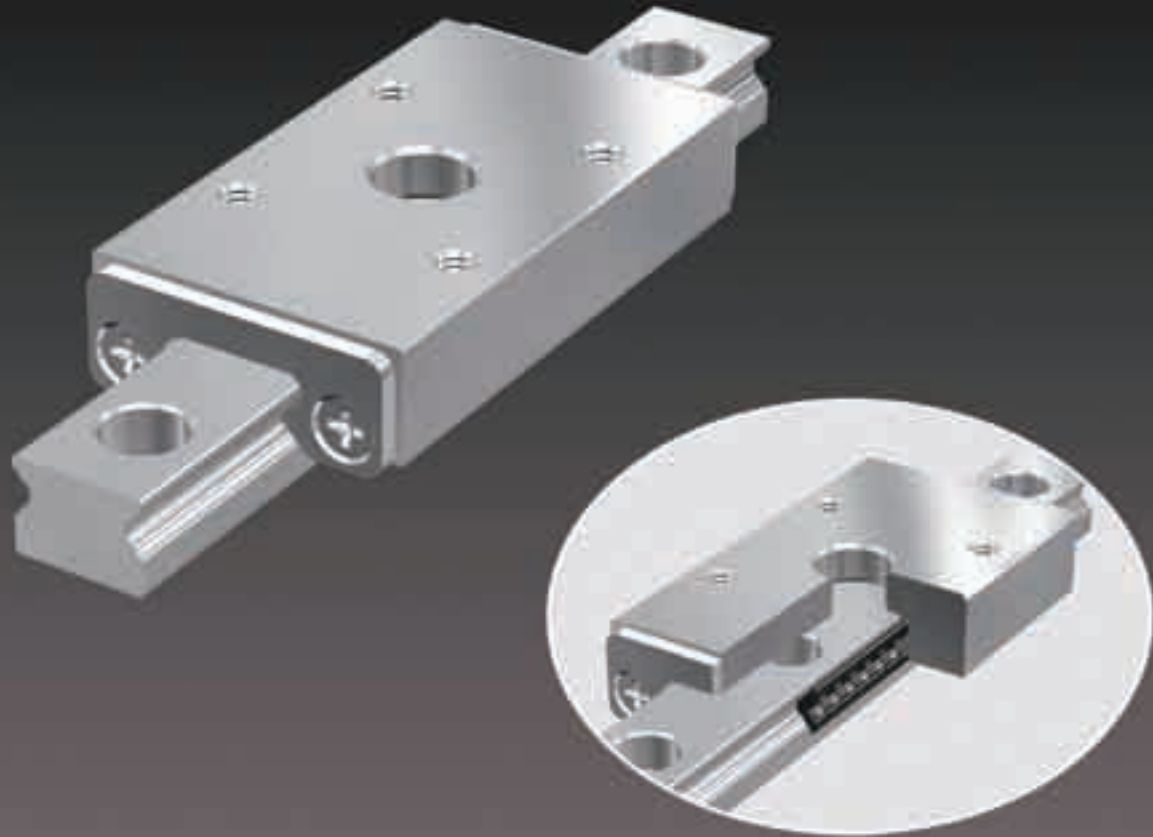

Ball Cage Effect

The early forms of ball bearings were full-ball types without ball cages. Friction between balls caused loud noise, made high-speed rotation impossible, and shortened the service life. Twenty years later, a Caged Ball design was developed for ball bearings. The new design enabled high-speed rotation at a low noise level and extended the service life, despite the reduced number of balls used. It marked a major development in the history of ball bearings.

Similarly, the quality of needle bearings was significantly improved by the caged needle structure.

With cage-less, full-ball types of ball bearings, balls make metallic contact with one another and produce loud noise. In addition, they rotate in opposite directions, causing the sliding contact between two adjacent balls to occur at a speed twice the ball-spinning rate. These factors result in severe wear and reduce the service life of the product.

In addition, without a cage, balls make point contact increasing bearing stress, thus facilitating breakage of the oil film. In contrast, each caged ball contacts the cage over a wide area. Therefore, the oil film does not break, the noise level is low and balls can rotate at a high speed, resulting in a long service life.

- Long Service Life and Long-term Maintenance-free Operation
- Superbly High Speed
- Low Noise, Acceptable Running Sound
- Smooth Motion
- Low Dust Generation



Rotary ball bearing

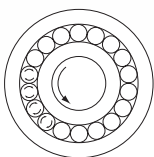

Conventional structure

- Adjacent balls contact each other at a point. As a result, contact stress is high and the oil film breaks due to friction.
- The service life becomes shorter.

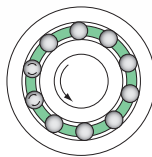

Caged Ball structure

- The service life is prolonged due to the elimination of wear caused by friction between balls.
- The absence of friction between balls results in reduced heat generation during high-speed rotation.
- The absence of friction between balls eliminates collision noise of the balls.
- The even spacing of the balls enables them to move smoothly.
- Retention of lubricant in the ball cage ensures a long service life.

Finite Stroke LM Guide

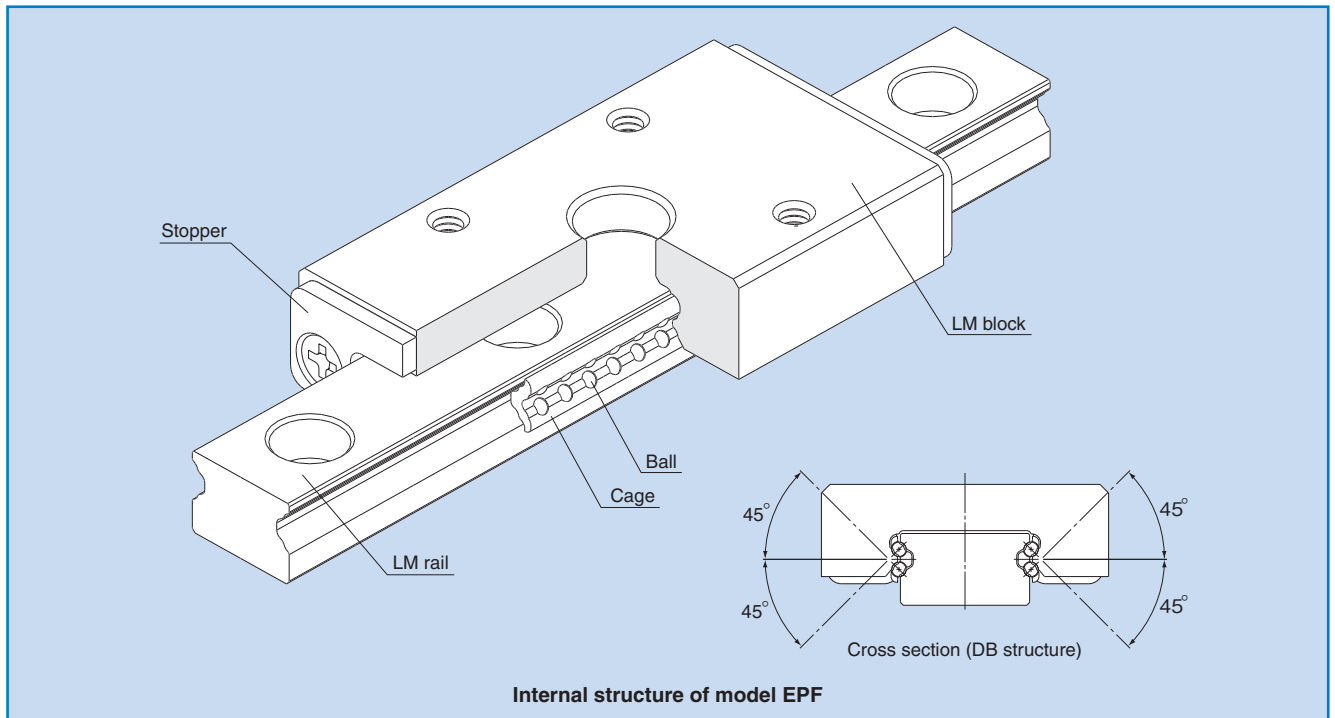

The spherically shaped cage holds the balls which rotate between the raceways of a precision ground LM rail and the 4 rows of circular arc grooves in the LM block.

● Smooth motion

Since its stroke is finite, the balls do not recirculate and travel smoothly even under a preload. In addition, fluctuation of the rolling resistance is minimum. Therefore, the product is optimal in places where a short stroke and smooth motion are required.

● High rigidity

Since model EPF adopts a DB structure in 4 rows of circular arc grooves, it has a high rigidity especially against a moment load in the M_c direction. Therefore, the product is optimal for use in places where an M_c moment is applied to a single axis.

● Miniature type

Since model EPF has the same mounting dimensions as miniature LM Guide model RSR-N, these models are interchangeable with each other.

● Four-way equal load

Each row of balls is placed at a contact angle of 45° so that the rated loads applied to the LM block are uniform in the four directions (radial, reverse-radial and lateral directions), enabling the LM Guide to be used in all orientations and in extensive applications.

Comparative test data on rolling resistance

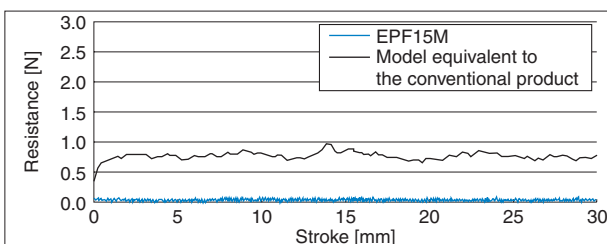
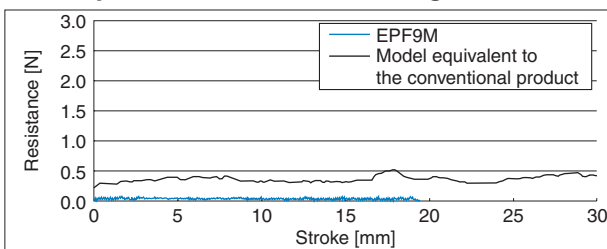

Comparative test data on M_c moment

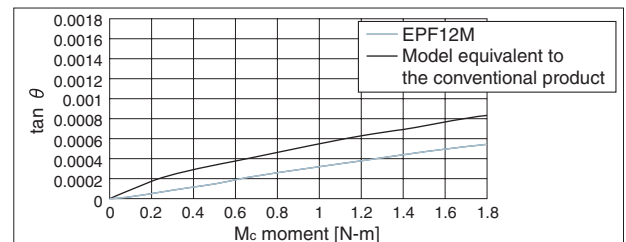
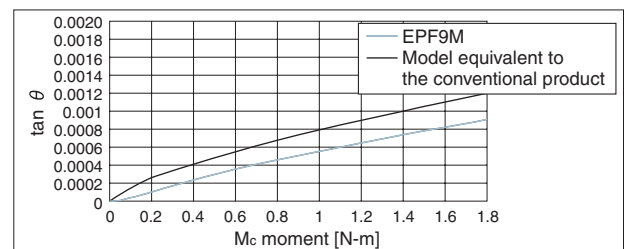

M_c moment: in the moment rolling direction

● Utilization of the Ball Cage Technology - 1

Since the cage is resin-molded, metal to metal contact between balls is eliminated, and acceptable running noise, low particle generation and long service life are achieved.

● Utilization of the Ball Cage Technology - 2

Since the cage is resin-molded into a spherical shape, the lubricant is retained in a grease pocket and long-term maintenance-free operation is achieved.

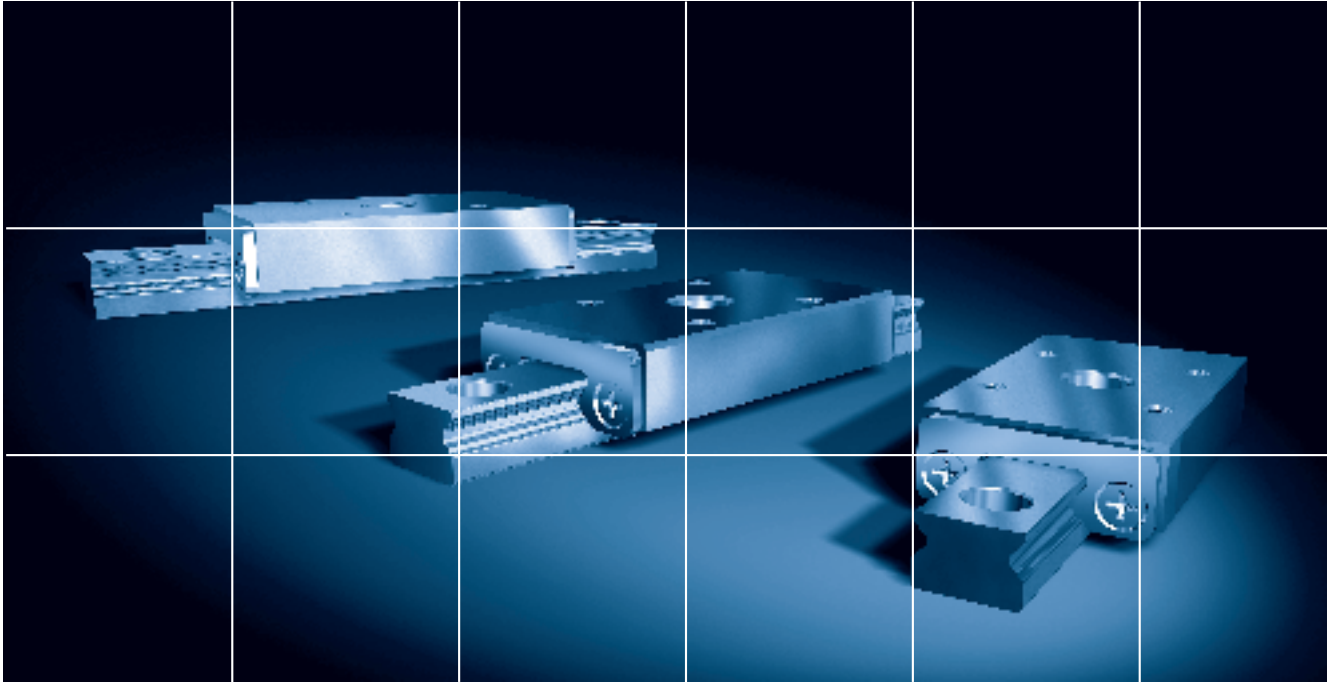

EPF Outline

Model EPF - Product Overview

Major Applications semiconductor manufacturing machines / medical equipment / industrial equipment, etc.

Model EPF

- EPF 7M
- EPF 9M
- EPF12M
- EPF15M

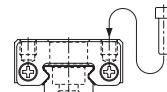
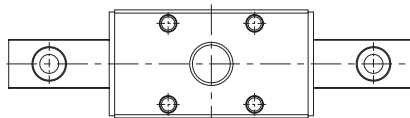

*1: Dimensional table for model EPF

→ See page 9.

Rated Loads in All Directions

Model EPF is capable of receiving loads in all four directions: radial, reverse-radial and lateral directions.

The basic load ratings are equal in the four directions (radial, reverse-radial and lateral directions). Their actual values are indicated in the dimensional table*1 for model EPF.

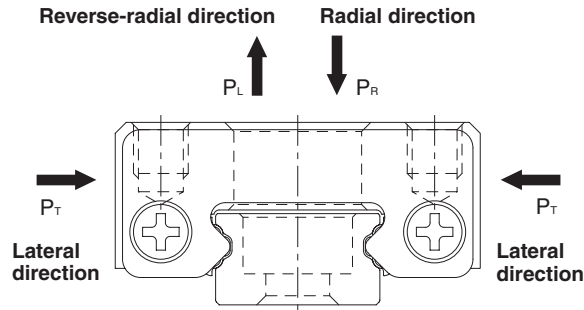

Equivalent Load

When the LM block of model EPF receives loads in the radial, reverse-radial and lateral directions simultaneously, the equivalent load is obtained in the equation below.

$$P_E = P_R (P_L) + P_T$$

P_E : Equivalent load (N)	P_R : Radial load (N)
• Radial direction	P_L : Reverse-radial load (N)
• Reverse-radial direction	P_T : Lateral load (N)
• Lateral direction	

Equivalent Load of Moment

When model EPF receives a moment, the equivalent load is obtained in the equation below.

$$P = K \cdot M$$

P : Equivalent load per LM Guide (N)	
K : Equivalent factor of moment (see Table 1)	
M : Load moment (N-mm)	

Table 1 Equivalent factor of moment

Model No.	K_A	K_B	K_C
EPF 7M	3.55×10^{-1}	3.55×10^{-1}	2.86×10^{-1}
EPF 9M	3.10×10^{-1}	3.10×10^{-1}	2.22×10^{-1}
EPF12M	2.68×10^{-1}	2.68×10^{-1}	1.67×10^{-1}
EPF15M	2.00×10^{-1}	2.00×10^{-1}	1.34×10^{-1}

K_A : Equivalent factor in the M_A radial direction when one LM block is used
 K_B : Equivalent factor in the M_B radial direction when one LM block is used
 K_C : Equivalent factor in the M_C radial direction
 : Equivalent factor in the M_A reverse-radial direction when one LM block is used
 Equivalent factor in the M_C reverse-radial direction

***1: Basic dynamic load rating (C)**

The basic dynamic load rating (C) indicates the load with constant direction and magnitude, under which the rated life (L) is 50 km when a group of the identical LM Guide units independently operating under the same conditions.

Service Life

The service life of each LM Guide unit manufactured in the same process is subject to slight variations even under the same operational conditions. Therefore, it is necessary to use the rated life defined below as a reference value for obtaining the service life of the LM Guide.

Rated Life

The rated life means the total travel distance that 90% of a group of identical LM Guide units can achieve without flaking (scale-like exfoliation on the metal surface) after individually running under the same conditions.

Service Life

When the rated life (L) has been obtained, the service life is obtained using the equation shown on the right, if the stroke length and the number of reciprocations are constant.

$$L = \left(\frac{f_H \cdot f_T \cdot f_C}{f_W} \cdot \frac{C}{P_C} \right)^3 \times 50$$

L : Rated life (km)
 C : Basic dynamic load rating*1 (N)
 P_C : Calculated load (N)
 f_H : Hardness factor (see Fig. 1)
 f_T : Temperature factor
 f_C : Contact factor
 f_W : Load factor (see Table 2)

$$L_h = \frac{L \times 10^6}{2 \times \ell_s \times n_1 \times 60}$$

L_h : Service life time (h)
 ℓ_s : Stroke length (mm)
 n₁ : Number of reciprocations per minute (min⁻¹)

f_H: Hardness factor

To ensure the achievement of the optimum load capacity of the LM Guide, the raceway's hardness must be between 58 and 64 HRC.

At hardness below this range, the basic dynamic and static load ratings decrease. Therefore, the rating values must be multiplied by the respective hardness factors (f_H).

Since the LM Guide has sufficient hardness, the f_H value for the LM Guide is normally 1.0.

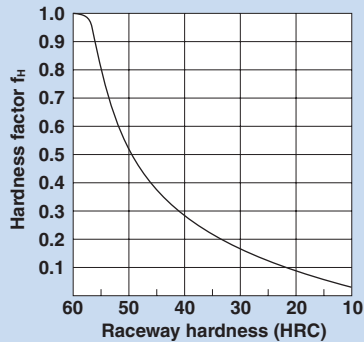

Fig. 1 Hardness factor (f_H)

f_C: Contact factor

The contact factor of finite stroke LM Guide model EPF is f_C = 1.0.

f_T: Temperature factor

Since the service temperature of finite stroke LM Guide model EPF is 80°C or below, the temperature factor is f_T = 1.0.

f_W: Load factor

In general, reciprocating machines tend to produce vibrations or impact during operation. In addition, it is difficult to accurately determine all vibrations generated during high-speed operation and impacts produced each time the machine starts and stops. Therefore, where the effects of velocity and vibration are estimated to be significant, divide the basic dynamic load rating (C) by a load factor selected from Table 2, which contains empirically obtained data.

Table 2 Load factor (f_W)

Vibration/impact	Velocity (V)	f _W
Faint	Hyper-slow V ≤ 0.25m/s	1 to 1.2
Weak	Slow 0.25 < V ≤ 1m/s	1.2 to 1.5
Moderate	Medium 1 < V ≤ 2m/s	1.5 to 2
Strong	Fast V > 2m/s	2 to 3.5

Radial Clearance Standard

The radial clearance of an LM Guide greatly affects its running accuracy, load carrying capacity and rigidity. The radial clearance of model EPF is optimally adjusted.

In general, selecting a negative clearance, (i.e., a preload*1 is applied) while taking into account possible vibrations and impact generated from reciprocating motion, favorably affects the service life and the accuracy.

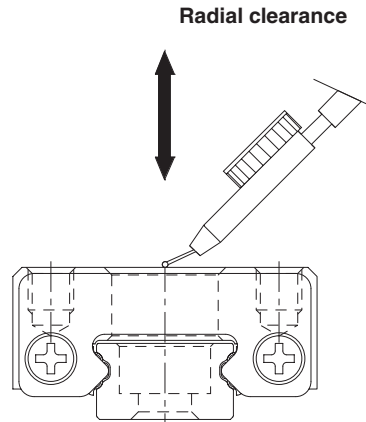

***1: Preload**

Preload is an internal load applied to the rolling elements (balls) of an LM block in advance in order to increase its rigidity. Since the clearance of model EPF is optimally adjusted before shipment, it is unnecessary to adjust the preload.

Unit: μm

Model No.	Radial clearance
EPF 7M EPF 9M EPF12M EPF15M	0 or below

Accuracy standard

Accuracy of model EPF is specified for each model number in terms of running parallelism*1 and dimensional tolerance for height and width, as well as height difference*2 required when two or more LM rails are mounted on the same plane.

Accuracy of model EPF is classified into Normal grade (no symbol), High-accuracy grade (H) and Precision grade (P), as indicated in the table below.

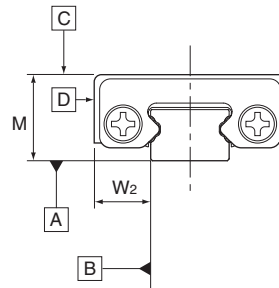

***1: Running parallelism**

It refers to a parallelism between the LM block and the LM rail datum plane when the LM block travels the whole length of the LM rail with the LM rail secured on the reference datum plane using bolts.

***2: Difference in height M**

It indicates a difference between the minimum and maximum values of height (M) of each of the LM blocks used on the same plane in combination.

Unit: mm

Model No.	Accuracy standard	Normal grade	High-accuracy grade	Precision grade
	Item	No symbol	H	P
EPF 7M EPF 9M EPF12M EPF15M	Dimensional tolerance for height M	± 0.04	± 0.02	± 0.01
	Difference in height M*3	0.03	0.015	0.007
	Dimensional tolerance for width W_2	± 0.04	± 0.025	± 0.015
	Running parallelism of surface C against surface A*4	0.008	0.004	0.001
	Running parallelism of surface D against surface B*4	0.008	0.004	0.001

*3: The accuracy measurements represent the values measured at the center point or central area of the LM block.

*4: If the stroke exceeds 40 mm, contact THK.

Shoulder Height of the Mounting Base and the Corner Radius

Normally, the mounting base for the LM rail and the LM block has a datum plane on the side face of the shoulder of the base in order to allow easy installation and highly accurate positioning.

The corner of the mounting shoulder must be machined to have a recess, or machined to be smaller than the corner radius “r,” to prevent interference with the chamfer of the LM rail or the LM block.

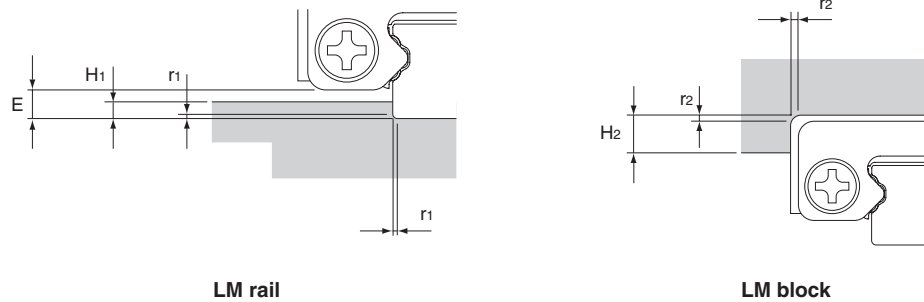

Unit: mm

Model No.	Corner radius of the LM rail r_1 (max)	Corner radius of the LM block r_2 (max)	Shoulder height of the LM rail H_1	Shoulder height of the LM block H_2	E
EPF 7M	0.2	0.4	1	3	1.5
EPF 9M	0.2	0.6	1	5	1.5
EPF12M	0.5	0.6	1.5	6	2
EPF15M	0.5	0.8	2.5	6.8	3

Accuracy of the Mounting Surface

If the mounting surface of the LM rail or the LM block is not accurately machined, the functions of the LM system may not be fully demonstrated. To achieve accuracy, machine the surface to at least the values indicated in the table below. (recommended value: 70% of the values in the table).

Unit: mm

Model No.	Flatness	
	LM rail mounting surface	LM block mounting surface
EPF 7M, 9M	0.015/200	0.015/200
EPF12M	0.025/200	0.025/200
EPF15M	0.035/200	0.035/200

Note: For the mounting material, we recommend using a highly rigid material such as cast iron.

If using a less rigid material such as aluminum, it may not withstand an unexpected load. Contact THK for details.

EPF

Standard LM Rail Length

The following table shows the standard LM rail lengths of model EPF.

We recommend the corresponding values for dimension G, as shown in the table below, for rails with non-standard lengths.

If the dimension G is longer, the respective part tends to become unstable after installation, which may adversely affect the accuracy.

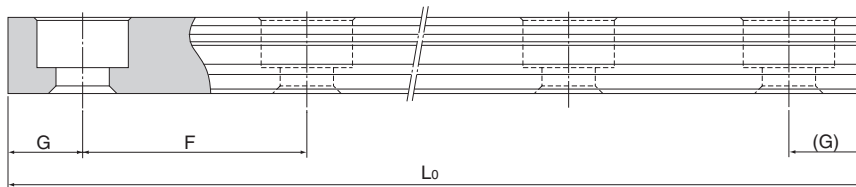

Standard LM rail lengths of model EPF

Unit: mm

Model No.	EPF 7M	EPF 9M	EPF 12M	EPF 15M
Standard LM rail length (L_0)	55	75	95	110
Standard pitch F	15	20	25	40
G	5	7.5	10	15

Note: LM rail lengths other than the standard LM rail lengths (L_0) may also be available. Contact THK for details.

EPF TYPE

Dimensional Table for Model EPF

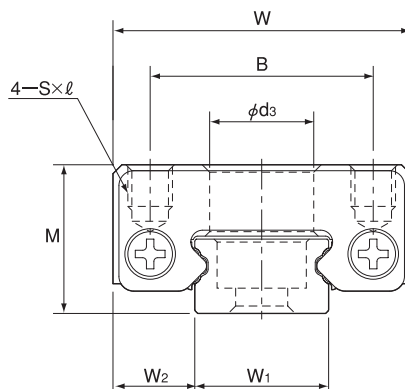

Model No.	External dimensions			LM block dimensions					LM rail dimensions				
	Height M	Width W	Length L _B	B	C	d ₃	S × l	L _{B1}	W ₁	W ₂	M ₁	G	F
EPF 7M	8	17	31.6	12	13	5	M2 × 2.3	29.6	7	5	5	5	15
EPF 9M	10	20	37.8	15	16	7	M3 × 2.8	35.8	9	5.5	5	7.5	20
EPF12M	13	27	43.7	20	20	7	M3 × 3.2	41.7	12	7.5	6.75	10	25
EPF15M	16	32	56.5	25	25	7	M3 × 3.5	54.5	15	8.5	9	15	40

Model number coding

EPF7M* 16 + 55L P M

Model number

LM rail length (in mm)

Rail material: stainless steel (standard)

Guaranteed stroke (in mm)

Accuracy symbol – see page 6

*: The material of the LM rail is stainless steel as standard.

Note This model number indicates that an LM rail and an LM block constitute one set.

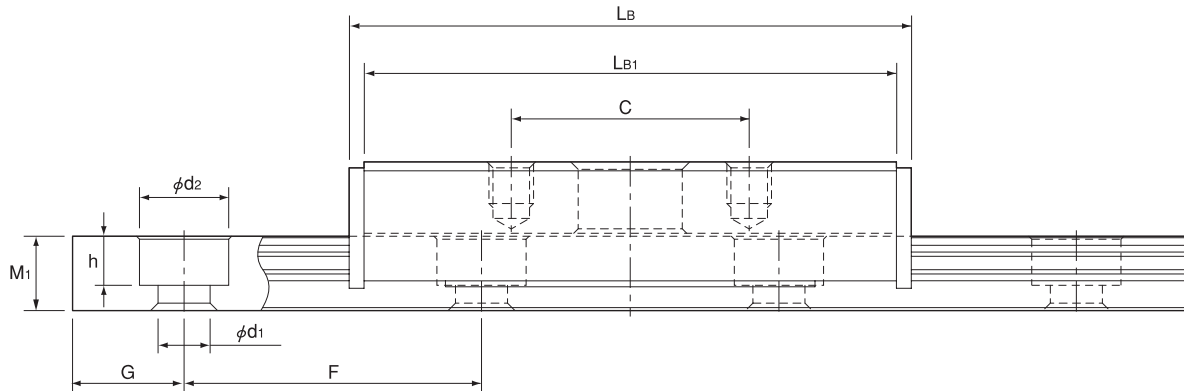

Unit: mm

Model No.	Dimensions	Guaranteed stroke	Basic load rating		Static permissible moment [N-m]			Mass	
			C	C ₀	M _{0A}	M _{0B}	M _{0C}	LM rail	LM block
	d ₁ × d ₂ × h	S _r	kN	kN				kg/m	kg
	2.4 × 4.2 × 2.6	16	0.90	1.60	5.08	5.08	5.26	0.230	0.019
	3.5 × 6 × 3.3	21	1.00	1.87	6.81	6.81	7.89	0.290	0.036
	3.5 × 6 × 3.8	27	2.26	3.71	15.5	15.5	20.8	0.550	0.074
	3.5 × 6 × 4	34	3.71	5.88	33.0	33.0	41.3	0.940	0.136

Note: AFJ Grease (THK original grease) is filled as standard grease.

Recommended tightening torque for the mounting bolt

Unit: N-m

Model No.	Nominal bolt size	Specified tightening torque value		
		Iron	Cast	Aluminum
EPF 7M	M2	0.588	0.392	0.294
EPF 9M	M3	1.96	1.27	0.98
EPF12M				
EPF15M				

Note

The cage holding balls moves extremely accurately. However, it may be displaced if it receives the machine's drive vibrations, inertial force or impact.

If you desire to use the product under the following conditions, contact THK.

- Vertical installation
- A large moment load is applied
- Stopping the LM block by letting the external stopper hit the table
- The product is used at high acceleration/deceleration

If the cage is displaced, it is necessary to force the cage back. The table on the right shows the sliding resistance required in such cases.

Make settings so that the thrust at or greater than the maximum value in the table is obtained.

Unit: N

Model No.	Maximum sliding resistance
EPF 7M	20
EPF 9M	20
EPF12M	30
EPF15M	30

THK Finite Stroke LM Guide Model EPF



Precautions on Use

● Precautions on handling

- Disassembling components may cause dust to enter the system or degrade the mounting accuracy of parts. Do not disassemble the product.
- Tilting the LM block or LM rail may cause them to fall by their own weights.
- Dropping or hitting the LM Guide may damage it. Applying an impact to the LM Guide could also cause damage to its function even if the guide looks intact.

● Lubrication

- Thoroughly remove anti-corrosion oil and feed a lubricant before using the product.
- Do not mix lubricants of different physical properties.
- In locations exposed to constant vibrations or in special environments such as clean rooms, vacuum and low/high temperature, normal lubricants may not be used. Contact THK for details.
- When planning to use a special lubricant, contact THK before using it.
- When adopting oil lubrication, the lubricant may not be distributed throughout the LM system depending on the mounting orientation of the system. Contact THK for details.
- Lubrication interval varies according to the service conditions. Contact THK for details.

● Precautions on use

- Entrance of foreign material may cause damage to the ball circulation path or functional loss. Prevent foreign material, such as dust or cutting chips, from entering the system.
- When planning to use the LM system in an environment where the coolant penetrates the LM block, it may cause trouble to the product functions depending on the type of the coolant. Contact THK for details.
- Do not use the LM system at temperature 80°C or higher. When desiring to use the system at temperature 80°C or higher, contact THK in advance.
- If foreign material such as dust and cutting chips adheres to the LM system, replenish the lubricant after cleaning the product. For available types of detergent, contact THK.
- When using the LM Guides with inverted installation, breakage of the stopper due to an accident or the like may cause balls to fall and the LM block to come off from the LM rail and fall. In these cases, take preventive measures such as adding a safety mechanism for preventing such falls.
- When using the LM system in locations exposed to constant vibrations or in special environments such as clean rooms, vacuum and low/high temperature, contact THK in advance.

● Storage

- When storing the LM Guide, enclose it in a package designated by THK and store it in a horizontal orientation while avoiding high temperature, low temperature and high humidity.

● “LM Guide,” “Caged Ball,” “,” and “QZ” are registered trademarks of THK CO., LTD.

- The photo may differ slightly in appearance from the actual product.
 - The appearance and specifications of the product are subject to change without notice. Contact THK before placing an order.
 - Although great care has been taken in the production of this catalog, THK will not take any responsibility for damage resulting from typographical errors or omissions.
 - For the export of our products or technologies and for the sale for exports, THK in principle complies with the foreign exchange law and the Foreign Exchange and Foreign Trade Control Law as well as other relevant laws.
- For export of THK products as single items, contact THK in advance.

All rights reserved

THK CO., LTD.

HEAD OFFICE 3-11-6, NISHI-GOTANDA, SHINAGAWA-KU, TOKYO 141-8503 JAPAN
INTERNATIONAL SALES DEPARTMENT PHONE:+81-3-5434-0351 FAX:+81-3-5434-0353

Global site : <http://www.thk.com/>

NORTH AMERICA

THK AMERICA, Inc.

● HEADQUARTERS

Phone:+1-847-310-1111 Fax:+1-847-310-1271

● CHICAGO OFFICE

Phone:+1-847-310-1111 Fax:+1-847-310-1182

● NEW YORK OFFICE

Phone:+1-845-369-4035 Fax:+1-845-369-4909

● ATLANTA OFFICE

Phone:+1-770-840-7990 Fax:+1-770-840-7897

● LOS ANGELES OFFICE

Phone:+1-949-955-3145 Fax:+1-949-955-3149

● SAN FRANCISCO OFFICE

Phone:+1-925-455-8948 Fax:+1-925-455-8965

● BOSTON OFFICE

Phone:+1-781-575-1151 Fax:+1-781-575-9295

● DETROIT OFFICE

Phone:+1-248-858-9330 Fax:+1-248-858-9455

● TORONTO OFFICE

Phone:+1-905-820-7800 Fax:+1-905-820-7811

SOUTH AMERICA

THK BRASIL LTDA.

Phone:+55-11-3767-0100 Fax:+55-11-3767-0101

EUROPE

THK GmbH

● EUROPEAN HEADQUARTERS

Phone:+49-2102-7425-0 Fax:+49-2102-7425-217

● DÜSSELDORF OFFICE

Phone:+49-2102-7425-0 Fax:+49-2102-7425-299

● STUTTGART OFFICE

Phone:+49-7150-9199-0 Fax:+49-7150-9199-888

● MÜNCHEN OFFICE

Phone:+49-8937-0616-0 Fax:+49-8937-0616-26

● U.K. OFFICE

Phone:+44-1908-30-3050 Fax:+44-1908-30-3070

● ITALY MILANO OFFICE

Phone:+39-039-284-2079 Fax:+39-039-284-2527

● ITALY BOLOGNA OFFICE

Phone:+39-051-641-2211 Fax:+39-051-641-2230

● SWEDEN OFFICE

Phone:+46-8-445-7630 Fax:+46-8-445-7639

● AUSTRIA OFFICE

Phone:+43-7229-51400 Fax:+43-7229-51400-79

● SPAIN OFFICE

Phone:+34-93-652-5740 Fax:+34-93-652-5746

● TURKEY OFFICE

Phone:+90-216-569-7123 Fax:+90-216-569-7050

THK FRANCE S.A.S.

Phone:+33-4-3749-1400 Fax:+33-4-3749-1401

CHINA

THK (CHINA) CO.,LTD.

● HEADQUARTERS

Phone:+86-411-8733-7111 Fax:+86-411-8733-7000

● SHANGHAI OFFICE

Phone:+86-21-6219-3000 Fax:+86-21-6219-9890

● BEIJING OFFICE

Phone:+86-10-6590-3259 Fax:+86-10-6590-3557

● CHENGDU OFFICE

Phone:+86-28-8526-8025 Fax:+86-28-8525-6357

● GUANGZHOU OFFICE

Phone:+86-20-8333-9770 Fax:+86-20-8333-9726

THK (SHANGHAI) CO.,LTD.

Phone:+86-21-6275-5280 Fax:+86-21-6219-9890

TAIWAN

THK TAIWAN CO.,LTD.

● TAIPEI HEAD OFFICE

Phone:+886-2-2888-3818 Fax:+886-2-2888-3819

● TAICHUNG OFFICE

Phone:+886-4-2359-1505 Fax:+886-4-2359-1506

● TAINAN OFFICE

Phone:+886-6-289-7668 Fax:+886-6-289-7669

KOREA

SEOUL REPRESENTATIVE OFFICE

Phone:+82-2-3468-4351 Fax:+82-2-3468-4353

SINGAPORE

THK LM SYSTEM Pte. Ltd.

Phone:+65-6884-5500 Fax:+65-6884-5550

INDIA

BANGALORE REPRESENTATIVE OFFICE

Phone:+91-80-2330-1524 Fax:+91-80-2314-8226

