



NEW

Oil-Free LM Guide for Special Environments

Optimum for use under a vacuum environment
(up to 10^{-6} Pa) where oil cannot be used

Newly developed: Dry Lubrication S-Compound Film
Low particle generation, low outgassing

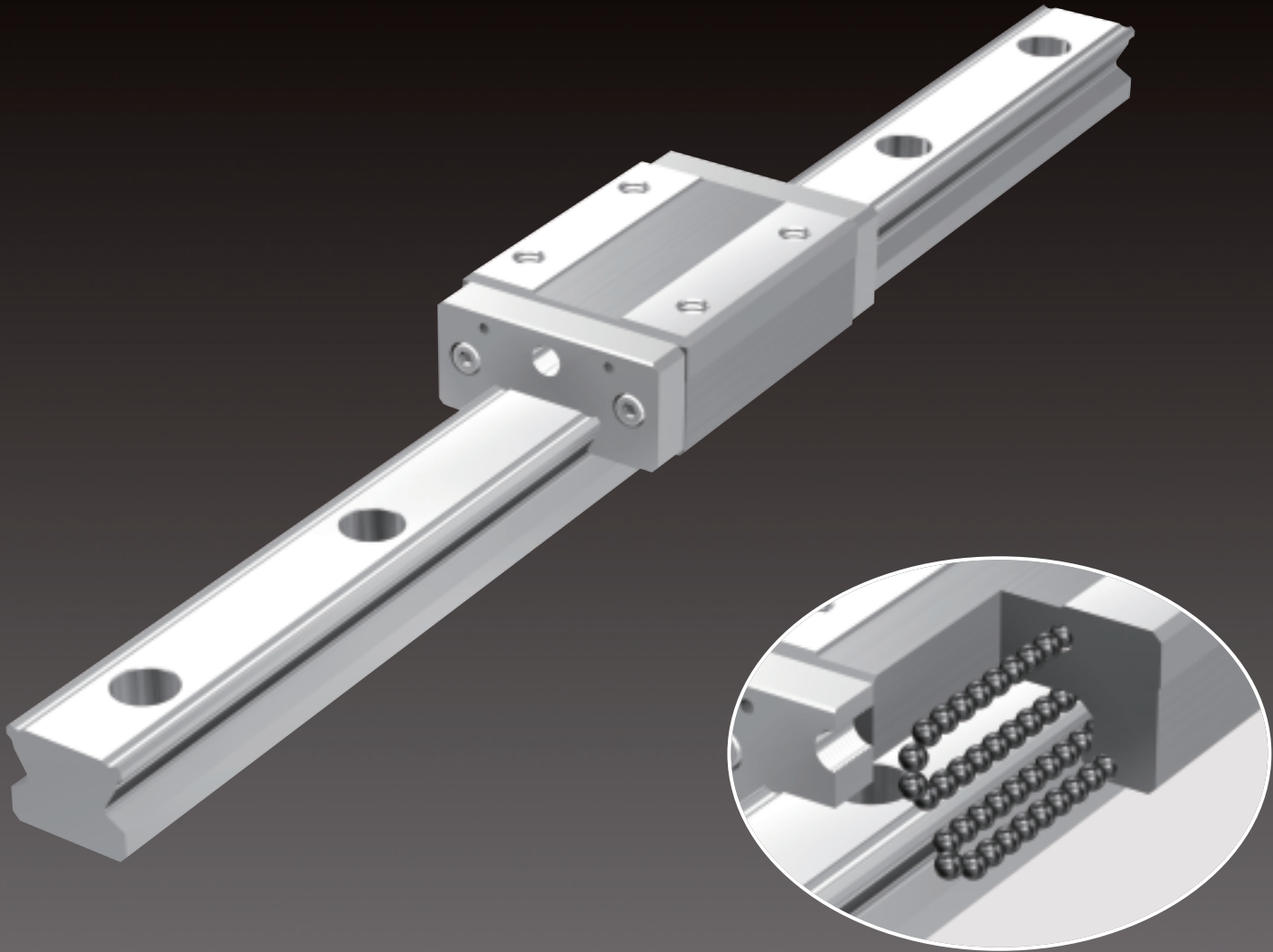

Oil-Free LM Guide for Special Environments

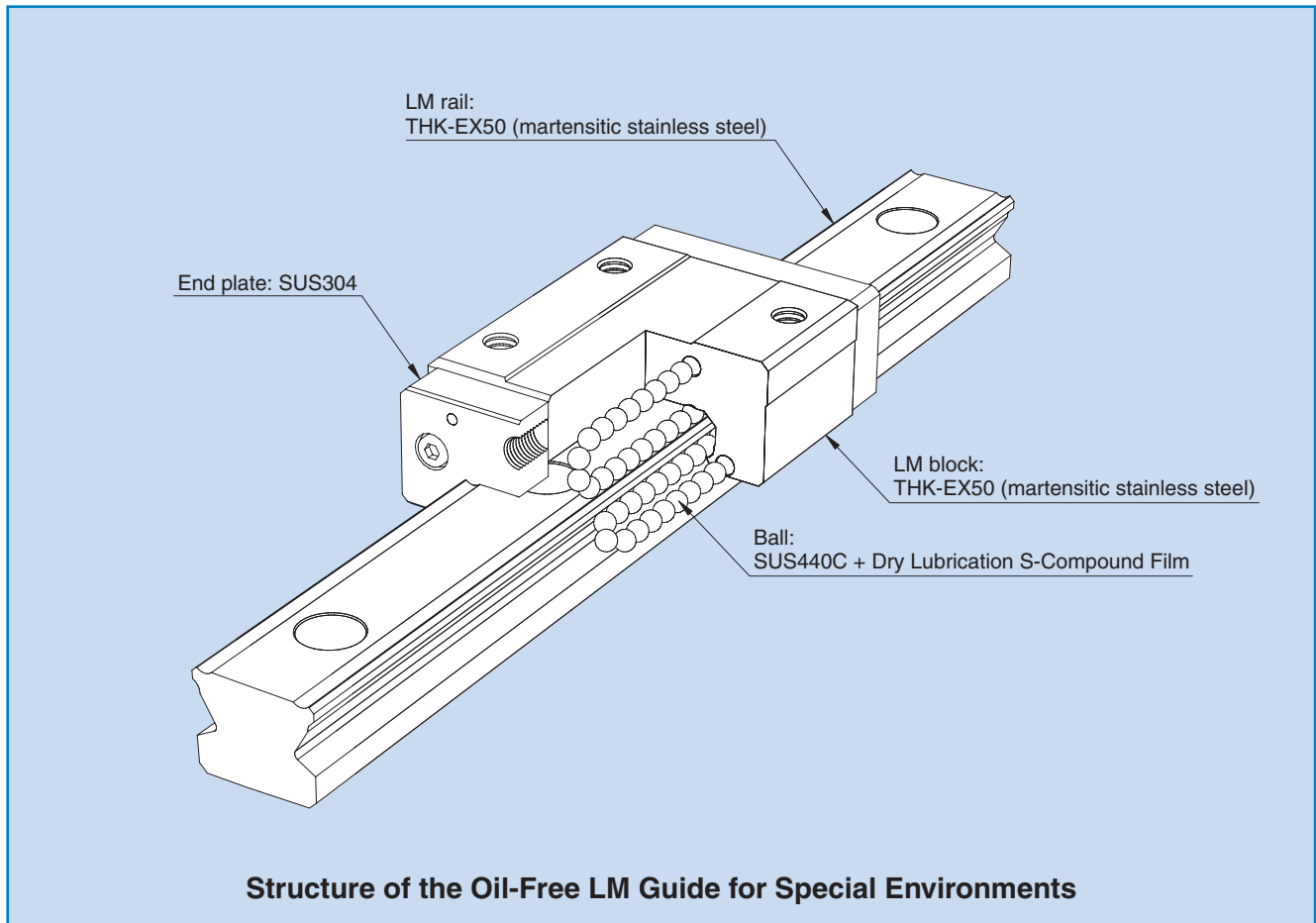

● Structural characteristics

1. Uses stainless steel
All components are made of stainless steel for special environment.
2. Degreased and cleaned
Special solvent is used to de-grease this solvent.
3. Does not use grease
The product does not use any grease, but adopts a highly reliable Dry Lubrication S-Compound Film.

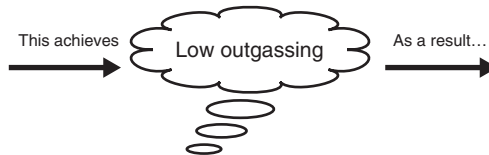

Largest advantage

Suitable for applications where the vacuum level reaches 10^6 Pa and chemical contamination (gaseous contamination such as organic matter and moisture) is not allowed.

*Can be used at temperature up to 150°C (instantaneously 200°C).

● What is Dry Lubrication S-Compound Film

Dry Lubrication S-Compound Film is a fully dry lubricant developed for use under atmospheric to high-vacuum environments. It has superior characteristics in load carrying capacity, wear resistance and sealability to other lubrication systems.

Comparison of dry lubrication material properties

Item	Friction coefficient	Wear resistance	Hardness	Service environment
Molybdenum Disulfide (hexagonal form)	0.04	△	△	Vacuum
Soft metal	0.05 to 0.5	△	△	Atmosphere, vacuum
DLC (diamond-like carbon)	0.08 to 0.15	△	○	Atmosphere, H ₂ O
Dry Lubrication S-Compound Film	0.02 to 0.05	○	○	Atmosphere, vacuum

● Low Friction

The Oil-Free LM Guide for special environments exerts superbly low frictional properties in atmospheric to vacuum environments.

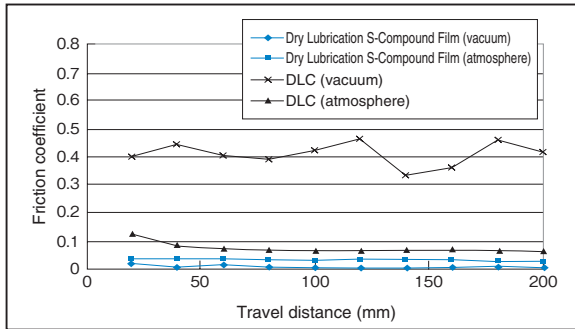

● Low Particle Generation

The Oil-Free LM Guide for special environments exerts a lower level of particle generation than conventional vacuum grease lubricants.

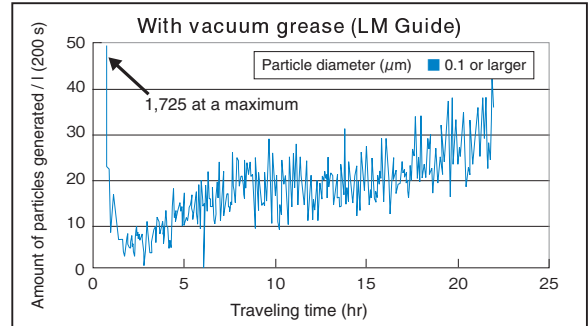
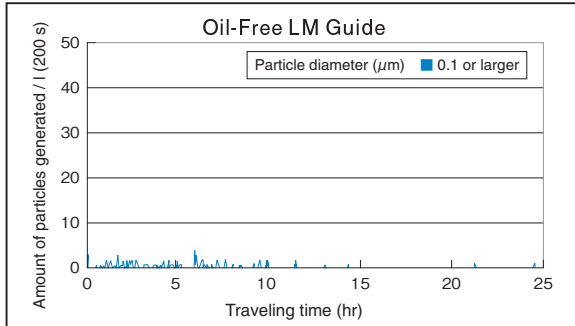

● Long Service Life

The Oil-Free LM Guide for special environments has a longer service life than conventional dry lubrication.

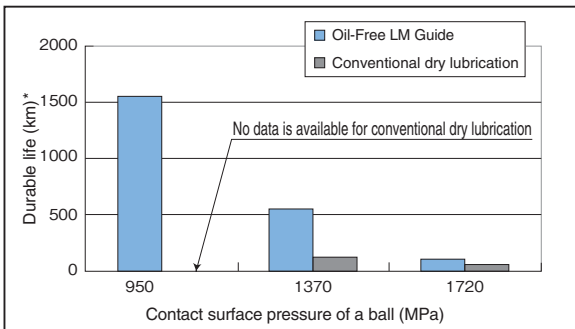

* The durable life represents the value at a point from which the Dry Lubrication S-Compound Film is no longer effective.

Note that the durable life differs from the rated service life of the LM Guide.

● Applications of the Oil-Free LM Guide for Special Environments

Industry	Equipment	Advantages of oil-free LM Guide
Semiconductor / FPD manufacturing machine	Exposure machine, organic EL manufacturing machine, ion injection machine	<ul style="list-style-type: none"> ● Little outgassing (water, organic matter) ● Low particle generation ● Operable at high temperature (up to 150°C)

Accuracy Standard

Accuracy of the Oil-Free LM Guide for special environments is classified into Precision (P), Super Precision (SP) and Ultra Precision (UP).

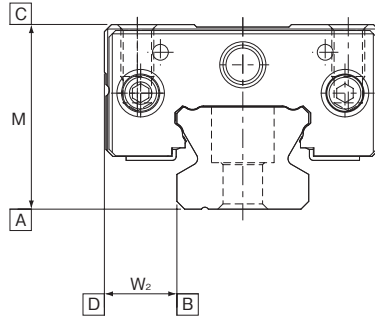

Unit: mm

Model number	Accuracy standard	Precision grade	Super Precision grade	Ultra Precision grade
	Item	P	SP	UP
SR15MSV/W SR20MSV/W	Dimensional tolerance in height M	0 -0.03	0 -0.015	0 -0.008
	Difference in height M	0.006	0.004	0.003
	Dimensional deviation in width W_2	0 -0.02	0 -0.015	0 -0.008
	Difference in width W_2	0.006	0.004	0.003
	Running parallelism of surface C against surface A	See the table below.		
	Running parallelism of surface D against surface B	See the table below.		

Unit: μm

LM rail length (mm)		Running parallelism value		
Above	Or less	Precision	Super Precision	Ultra Precision
		P	SP	UP
—	50	2	1.5	1
50	80	2	1.5	1
80	125	2	1.5	1
125	200	2	1.5	1
200	250	2.5	1.5	1
250	315	3	1.5	1
315	400	3.5	2	1.5

Radial clearance

Radial clearance of the Oil-Free LM Guide for special environments is defined with the values in the table below.

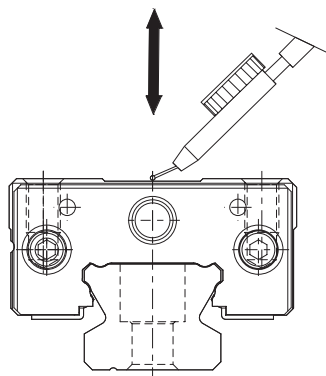

Unit: mm

Model number	Clearance CS
SR15MSV/W	-0.002 to 0.001
SR20MSV/W	-0.002 to 0.001

Shoulder height of the mounting surface and the corner radius

Normally, the mounting surface for the LM block and the LM rail has a datum plane on the side face in order to allow easy installation and highly accurate positioning.

The corner of the mounting surface must be machined to have a recess, or machined to be smaller than the corner radius “r,” to prevent interference with the chamfer of the LM block or the LM rail.

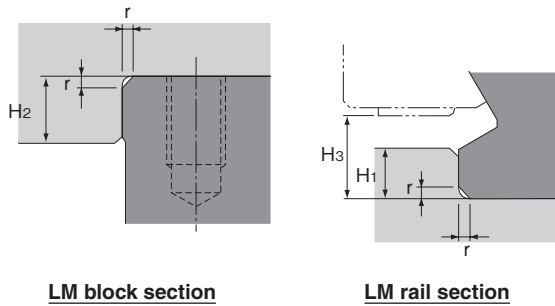

LM block section

LM rail section

Unit: mm

Model number	Corner radius r (maximum)	Shoulder height of the LM rail section H ₁	Shoulder height of the LM block section H ₂	H ₃
SR15MSV/W	0.5	3.8	4	4.5
SR20MSV/W	0.5	5	5	6

Tolerance in parallelism between 2 rails

The following table shows the tolerance in parallelism (P) between 2 rails.

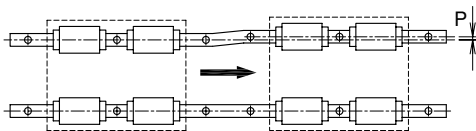

Unit: μm

Model number	Clearance CS
SR15MSV/W	8
SR20MSV/W	8

Tolerance in vertical level between 2 rails

The following table shows the tolerance in vertical level (S) between 2 rails per axis-to-axis distance of 200 mm. The tolerance in vertical level is proportionate to the axis-to-axis distance.

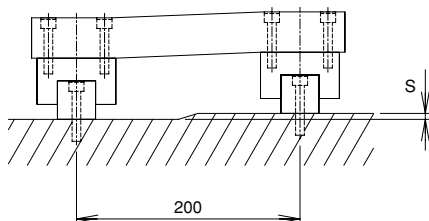

Unit: mm

Model number	Clearance CS
SR15MSV/W	0.020/200
SR20MSV/W	0.020/200

Flatness of the mounting surface

The following table shows the flatness of the mounting surface.

Unit: mm

Model number	Clearance CS
SR15MSV/W	0.020/200
SR20MSV/W	0.020/200

Model SR-MSV/W

Dimensional table for models SR-MSV/W

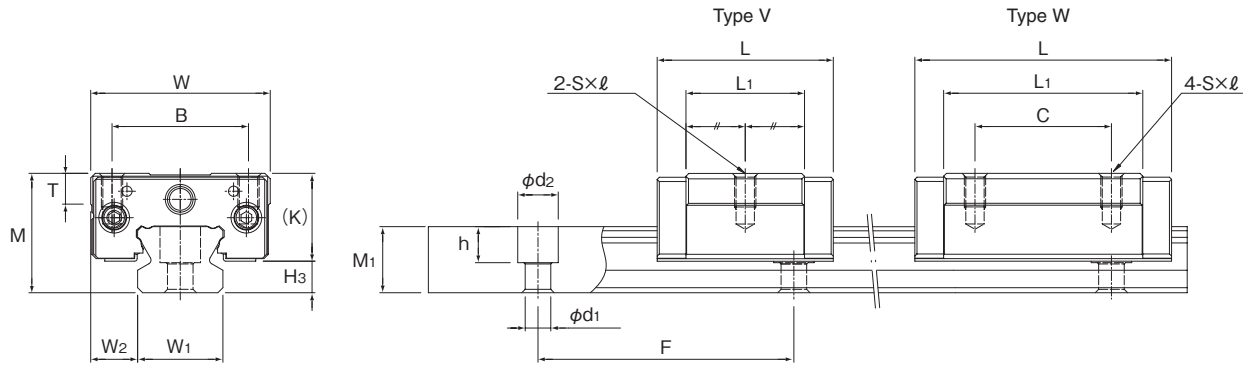

Unit: mm

Model No.	Outer dimensions			LM block dimensions						H ₃
	Height M	Width W	Length L	B	C	S×ℓ	L ₁	T	K	
SR15MSV	24	34	36.6	26	—	M4×7	22.9	5.7	19.5	4.5
SR15MSW			53.2		26		39.5			
SR20MSV	28	42	41.3	32	—	M5×8	27.8	7.2	22	6
SR20MSW			60.2		32		46.7			

Unit: mm

Model No.	LM rail dimensions					Basic load rating F ₀ [N]	Static permissible moment [N·m]					Mass	
	Width W ₁ ±0.05	W ₂	Height M ₁	Pitch F	d ₁ ×d ₂ ×h		M _A	M _B	M _C	M _D	LM block [kg]	LM rail [kg/m]	
	SR15MSV	15	9.5	12.5	60	3.5×6×4.5	320	0.80	5.43	0.51	3.60	1.16	0.12
SR15MSW	570						2.35	13.0	1.47	8.31	2.08	0.2	
SR20MSV	20	11	15.5	60	6×9.5×8.5	430	1.35	8.44	0.87	5.52	2.05	0.2	2.1
SR20MSW						750	3.76	19.9	2.36	12.6	3.59	0.3	

Note 1: If you desire a product other than the model numbers indicated above, contact THK.

Note 2: For durability of the Oil-Free LM Guide for special environments, contact THK.

Example of model number coding

SR15MSV 1 CS + 300L P - II

Model number

LM rail length (mm)

Number of rails used on the same plane

Number of LM blocks on one rail

Radial clearance symbol

Accuracy symbol

Note With this model, a single-rail unit constitutes one set (i.e., the required number of sets when 2 rails are used in parallel is 2).

Standard length and maximum length of the LM rail

The following table shows the standard length and the maximum length of the LM rail of the Oil-Free LM Guide for special environments. If the overall rail length exceeds the maximum length, contact THK.

For dimension G if you require a special length, we recommend using the dimensions in the table. If dimension G is longer, the respective part tends to become unstable after installation, which may negatively affect the accuracy.

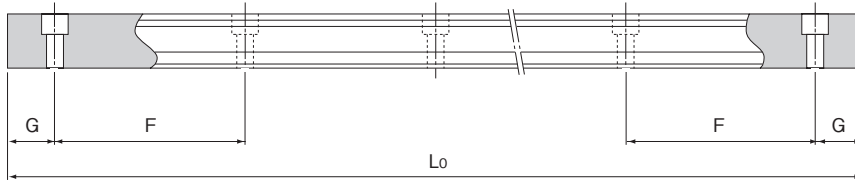

Standard length and maximum length of the LM rail

Unit: mm

Model number	SR15MSV/W	SR20MSV/W
Standard LM rail Length (L_0)	160	220
	220	280
	280	340
	340	400
	400	
Standard pitch F	60	60
G	20	20
Maximum length	400	400

Note 1: If you desire a rail length larger than the maximum length, contact THK.

Note 2: A connected-rail type is not available.

THK Oil-Free LM Guide for Special Environments

Precautions on Use

● Handling

- Pulling out the LM block from the LM rail will cause balls to fall, or damage the Dry Lubrication S-Compound Film when reattaching the LM block. If it is necessary to remove the LM block from the LM rail, contact THK.
- Do not disassemble the parts. Doing so may cause entrance of dust or a functional loss.
- Tilting the LM block or the LM rail may cause it to fall by its own weight.
- Do not drop or hit the LM Guide. Doing so may cause injury. It may also cause failure or breakage. Applying an impact to the product may cause a functional loss even if it may look intact.
- The product is provided with moisture-proof packaging after thoroughly degreased and cleaned. Unpack the product immediately before use whenever it is possible.
- After unpacking the product, store it in a clean dry container together with a desiccant (e.g., silica gel). Do not apply anticorrosive oil or use volatile corrosion inhibitor paper (agent).
- When handling the product, use vinyl gloves or the like in a clean place.

● Service temperature range

- The maximum service temperature of the product is 150°C (instantaneously 200°C).

● Service environment and lubrication

- Use this product in a clean place under an environment at pressure from atmosphere pressure to vacuum (10⁻⁶ Pa).
- This product is coated with Dry Lubrication S-Compound Film. The Dry Lubrication S-Compound Film has superb performance in load carrying capacity, wear resistance and sealability in atmospheric to vacuum environments. However, it will be worn as the LM block and the LM rail travel. For durability of the Dry Lubrication S-Compound Film, contact THK.

● Storage

- When storing the product, enclose it in a package designated by THK and store it in a horizontal orientation in a place controlled to a constant environment while avoiding high temperature, low temperature and high humidity. We recommend normal temperature (25°C ±5°C), humidity 40% RH or below, and cleanliness at 10000 or below.

● “LM GUIDE” and “” are registered trademarks of THK CO., LTD.

- The photo may differ slightly in appearance from the actual product.
 - The appearance and specifications of the product are subject to change without notice. Contact THK before placing an order.
 - Although great care has been taken in the production of this catalog, THK will not take any responsibility for damage resulting from typographical errors or omissions.
 - For the export of our products or technologies and for the sale for exports, THK in principle complies with the foreign exchange law and the Foreign Exchange and Foreign Trade Control Law as well as other relevant laws.
- For export of THK products as single items, contact THK in advance.

All rights reserved

THK CO., LTD.

HEAD OFFICE 3-1-1-6, NISHI-GOTANDA, SHINAGAWA-KU, TOKYO 141-8503 JAPAN
INTERNATIONAL SALES DEPARTMENT PHONE:+81-3-5434-0351 FAX:+81-3-5434-0353
Global site : <http://www.thk.com/>

NORTH AMERICA

THK America, Inc.
● HEADQUARTERS
Phone:+1-847-310-1111 Fax:+1-847-310-1271
● CHICAGO OFFICE
Phone:+1-847-310-1111 Fax:+1-847-310-1182
● NEW YORK OFFICE
Phone:+1-845-369-4035 Fax:+1-845-369-4909
● ATLANTA OFFICE
Phone:+1-770-840-7990 Fax:+1-770-840-7897
● LOS ANGELES OFFICE
Phone:+1-949-955-3145 Fax:+1-949-955-3149
● SAN FRANCISCO OFFICE
Phone:+1-925-455-8948 Fax:+1-925-455-8965
● BOSTON OFFICE
Phone:+1-781-575-1151 Fax:+1-781-575-9295
● DETROIT OFFICE
Phone:+1-248-858-9330 Fax:+1-248-858-9455
● TORONTO OFFICE
Phone:+1-905-820-7800 Fax:+1-905-820-7811

SOUTH AMERICA

THK Brasil LTDA
Phone:+55-11-3767-0100 Fax:+55-11-3767-0101

EUROPE

THK GmbH
● EUROPEAN HEADQUARTERS
Phone:+49-2102-7425-0 Fax:+49-2102-7425-217
● DÜSSELDORF OFFICE
Phone:+49-2102-7425-0 Fax:+49-2102-7425-299

● FRANKFURT OFFICE

Phone:+49-2102-7425-650 Fax:+49-2102-7425-699

● STUTTGART OFFICE

Phone:+49-7150-9199-0 Fax:+49-7150-9199-888

● MÜNCHEN OFFICE

Phone:+49-8937-0616-0 Fax:+49-8937-0616-26

● U.K. OFFICE

Phone:+44-1908-30-3050 Fax:+44-1908-30-3070

● ITALY MILANO OFFICE

Phone:+39-039-284-2079 Fax:+39-039-284-2527

● ITALY BOLOGNA OFFICE

Phone:+39-051-641-2211 Fax:+39-051-641-2230

● SWEDEN OFFICE

Phone:+46-8-445-7630 Fax:+46-8-445-7639

● AUSTRIA OFFICE

Phone:+43-7229-51400 Fax:+43-7229-51400-79

● SPAIN OFFICE

Phone:+34-93-652-5740 Fax:+34-93-652-5746

● TURKEY OFFICE

Phone:+90-216-362-4050 Fax:+90-216-569-7150

● PRAGUE OFFICE

Phone:+420-2-41025-100 Fax:+420-2-41025-199

THK France S.A.S.

Phone:+33-4-3749-1400 Fax:+33-4-3749-1401

CHINA

THK (CHINA) CO.,LTD.

● HEADQUARTERS

Phone:+86-411-8733-7111 Fax:+86-411-8733-7000

● SHANGHAI OFFICE

Phone:+86-21-6219-3000 Fax:+86-21-6219-9890

● BEIJING OFFICE

Phone:+86-10-8441-7277 Fax:+86-10-6590-3557

● CHENGDU OFFICE

Phone:+86-28-8526-8025 Fax:+86-28-8525-6357

● GUANGZHOU OFFICE

Phone:+86-20-8523-8418 Fax:+86-20-3801-0456

THK (SHANGHAI) CO.,LTD.

Phone:+86-21-6275-5280 Fax:+86-21-6219-9890

TAIWAN

THK TAIWAN CO.,LTD.

● TAIPEI HEAD OFFICE

Phone:+886-2-2888-3818 Fax:+886-2-2888-3819

● TAICHUNG OFFICE

Phone:+886-4-2359-1505 Fax:+886-4-2359-1506

● TAINAN OFFICE

Phone:+886-6-289-7668 Fax:+886-6-289-7669

KOREA

SEOUL REPRESENTATIVE OFFICE

Phone:+82-2-3468-4351 Fax:+82-2-3468-4353

SINGAPORE

THK LM SYSTEM Pte. Ltd.

Phone:+65-6884-5500 Fax:+65-6884-5550

INDIA

BANGALORE REPRESENTATIVE OFFICE

Phone:+91-80-2330-1524 Fax:+91-80-2314-8226

